



EUCOM Humanitarian Assistance Program

Renovations to School#05 - Sevastopol

Sevastopol, Ukraine
OHASIS ID-20420

June 2013

1. PROJECT DESCRIPTION

1.1. GENERAL

Provide all material, equipment and labor to renovate School#05 in Sevastopol (Ukraine), as identified herein.

1.2. GENERAL SCOPE OF WORK

The work is divided into a BASE-BID and 4 CONTRACT OPTIONS. The Government reserves the right to unilaterally award, or not to award, the contract options. The contractor will provide separate pricing for the Base-Bid and the 4 contract options as required in the solicitation documents.

Base Bid:

- Repair of a section of the roof (Central Wing)
- Repair of bathrooms (total 8 units)
- Repair of gymnasium and locker rooms
- Commemorative plaque

Option-1: Repair of sewer system

Option-2: Renovate front façade, including entrance

Option-3: Additional window replacement (Central Wing)

Option-4: Additional roof repair (West Wing and Hallway)

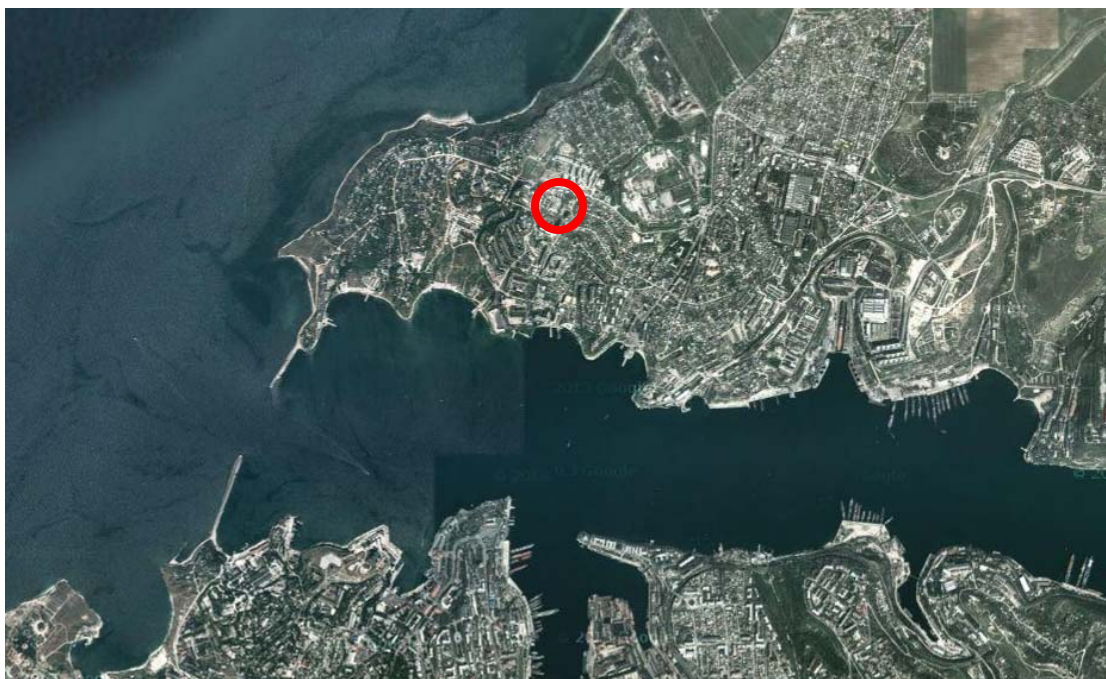

Picture#01: Location of School#05 in Sevastopol

It is absolutely necessary for the contractor to visit the site in order to verify existing conditions and quantify the amount of work, prior to the submission of their offers to the Contracting Officer. These Performance Technical Specifications (PTS) does not include measurement. The US Government is not responsible for any mistakes or omissions that the contractor may have made during preparation of their offers.



Picture#02: School#05 in Sevastopol

For the purposes of this PTS, the school under renovation is called “School#05”. However, the official name of the school is “Gymnasium Number 5” as seen in Picture#03. For the purposes of this PTS, “School#05” is the name of the school, and the “gymnasium” corresponds to the indoors physical education area



Picture#03: School#05 sign

1.3. DETAILED SCOPE OF WORK (BASE BID)

This portion of the contract described in paragraph 1.3 and all its subparagraphs corresponds to the minimum portion of the contract that will be awarded to the successful offeror.

1.3.1. Repair of a Section of the Roof (Central Wing)

The contractor shall repair the indicated sections of roof in order to provide 10 year warranty against any water or humidity infiltration. The works include all the roof surfaces of the Central wing, as well as the roof of the entrance canopy.

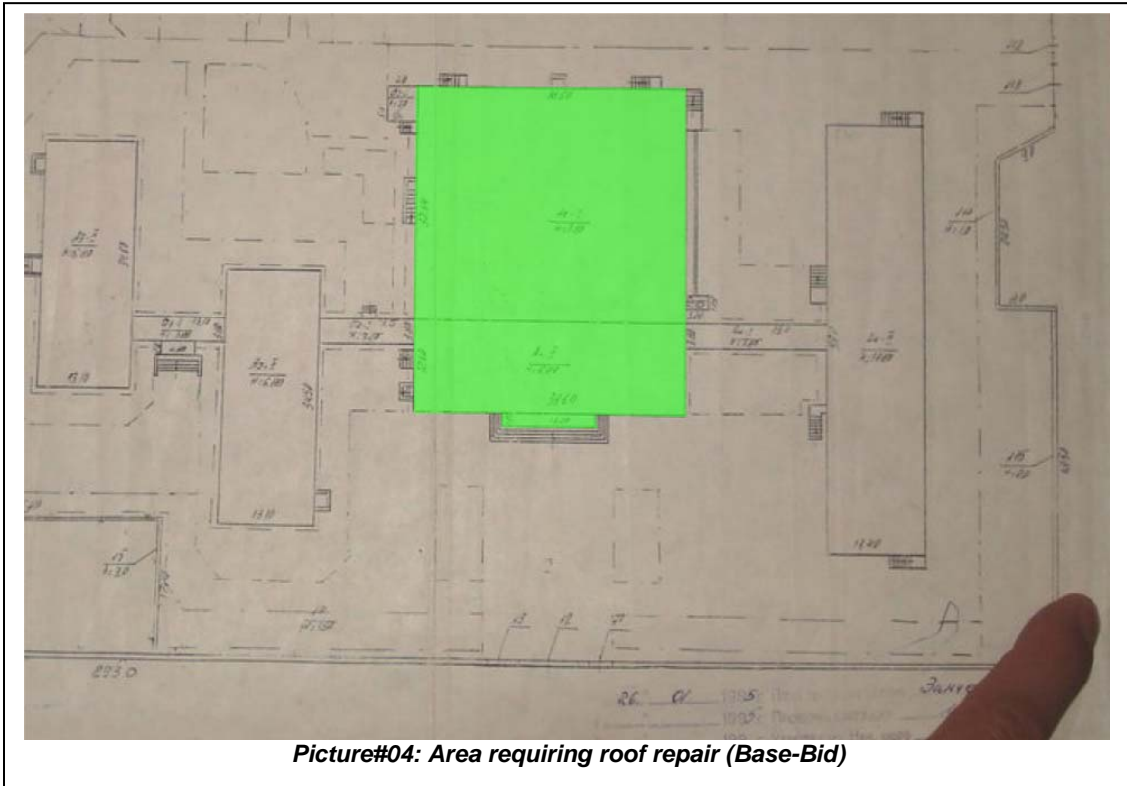

Picture#04: Area requiring roof repair (Base-Bid)

Complete Replacement of the roof waterproofing system:

In the green highlighted areas of picture#04, the contractor shall remove the existing roof waterproofing system and shall provide a two-ply modified bitumen roof system.

Repairs include the replacement of the metal covering of the building joints and the covers of the ventilation system.

Provide top layer with granular surface. Color of the finished surface to be green unless otherwise selected by the School Director.

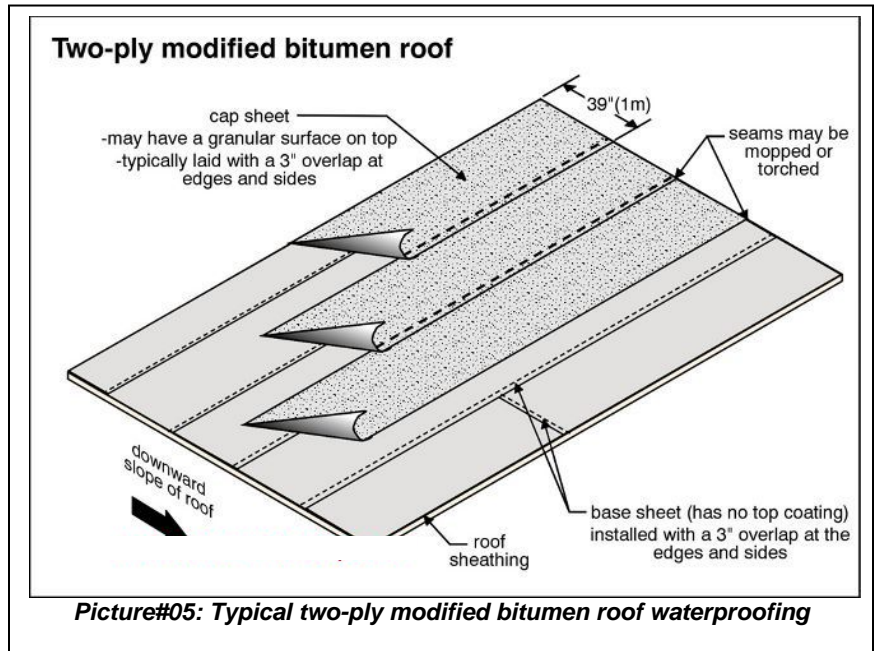

General Requirements for Roof Repairs: The contractor shall provide a 10 year warranty in the "green" highlighted areas of the school building as indicated in picture#04. The contractor shall choose the roof repair method to be accepted by the Contracting Officer Representative. A minimum of 2 layers of modified bituminous with granular finish is required for the "green" areas. The contractor shall repair the flashing and metal covers of the parapets in the roof and reinforce the connection between the horizontal and vertical surfaces. The contractor shall repair the stone or concrete parapets of the roof.

The contractor shall verify proper slopes of the roof surface to avoid any accumulation of water. Any area with accumulation of water shall be provided with proper slopes. In order to accomplish this, the contractor may have to provide light mortar layer after the removal of the existing waterproofing system, and prior to the application of the new waterproofing system.

All openings for ventilation shall be repaired and provided with new painted metal cover, extending a minimum of 30 cm over the perimeter of the opening.

There are no detailed pictures available of the existing roofing surfaces. For this reason, it is imperative that the contractor visits and inspects the site before submitting their offers.

Payment for the roof repair shall not be authorized until this item of work is completed, certified and provided with the official 10 year warranty against any water infiltration in the areas under renovation.

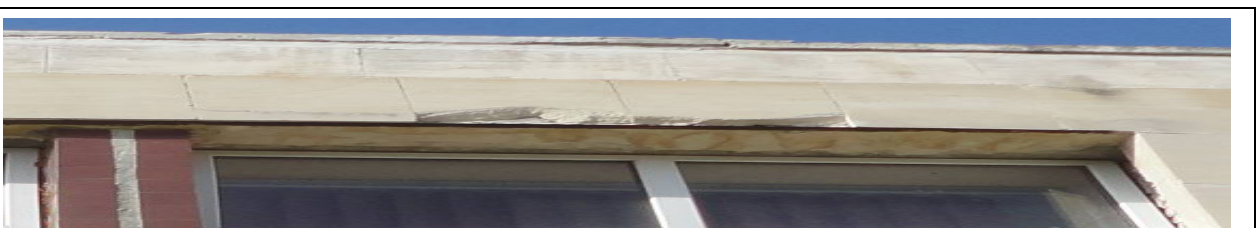

Picture#06: Stone and concrete parapets to be repaired under the roof repair portion of the PTS

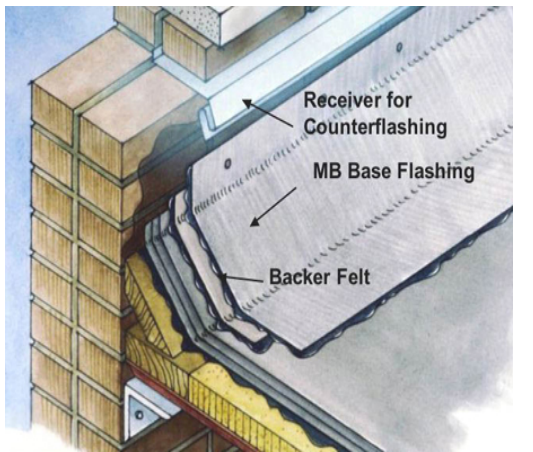

Picture#07: Reinforce the edges of the roof surfaces



Picture#08: Typical roofing work



Picture#09: Typical required finish



Picture#10: Roofing area to be repaired



Picture#11: Roofing area to be repaired.

1.3.2. Repair of Bathrooms (Central and West Wings)

The contract includes in the Base-Bid the complete renovation the following existing bathroom/toilet facilities:

- West Wing: (6 bathrooms). This includes 2 separate bathrooms on each floor. Boys bathroom and combined girls/teachers bathroom. Some of these rooms, originally designed and built to be used as bathrooms, have not been used in many years, and they are currently used as storage or they have a different use. The contractor shall visit the site in order to see the condition of each one of the 6 areas to be converted into modern bathroom facilities.
- Central Wing: (2 bathrooms). This includes one for boys and one for girls, adjacent to the gymnasium area.

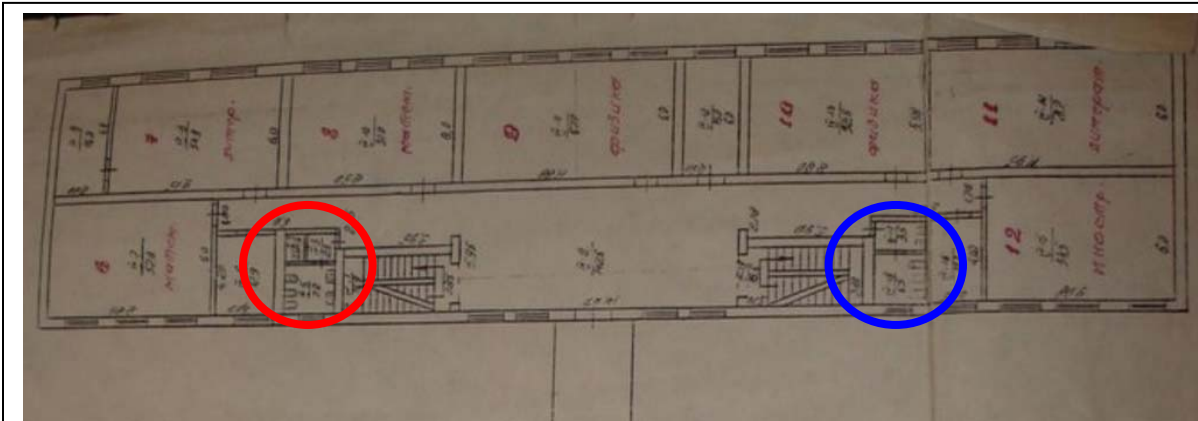

Picture#12: West Wing drawing showing location of bathrooms to be renovated. All 3 floors are similar.

Red: Girls and teachers
Blue: Boys

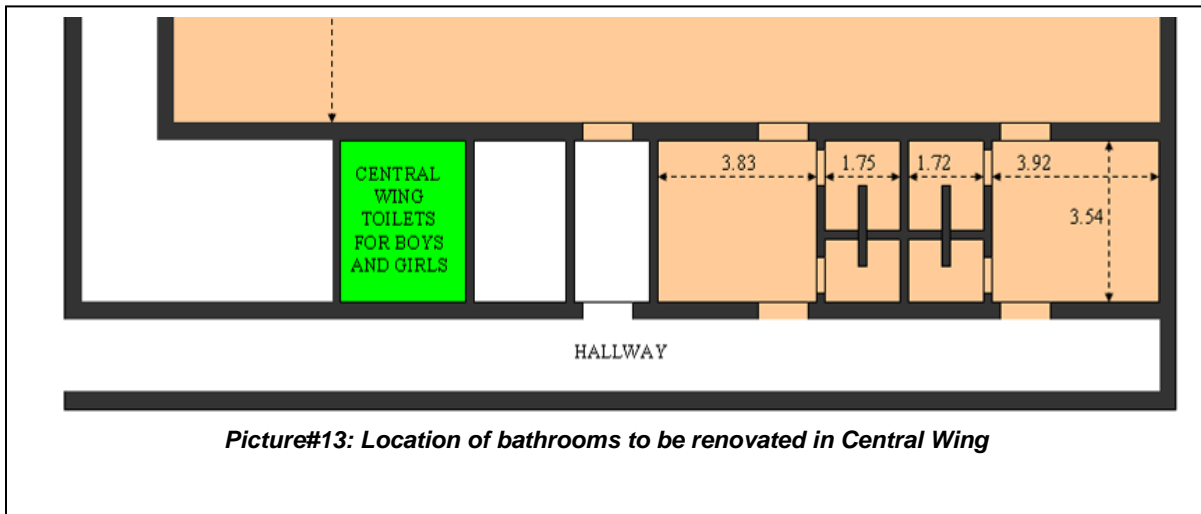

Picture#13: Location of bathrooms to be renovated in Central Wing

Once the project is completed, the 8 renovated bathrooms under the scope of work of this project shall have the appearance of completely new and high quality bathroom facilities. The work includes, but is not limited to the following:

Note: Prior to start of renovation works, the contractor shall provide a sketch to the Contracting Officer Representative for acceptance. In previous projects, there has been problems such as: improper selection of toilet fixtures (too large for reduced space), improper ventilation, improper mirrors, improper aluminum partitions, or improper ceramic tiles. The contractor shall provide to the Contracting Officer representative a clear sketch or draft design indicating their proposed design meeting the requirements of this contract and the requirements of the Ukrainian regulations.

- **Demolitions:** Remove everything inside of the bathrooms, including but not limited to floor and wall tiles, plumbing fixtures, some masonry partitions, electrical installation, windows, doors, water and sewage plumbing, ventilation, heating and everything within the areas to be renovated.
- **Exterior Windows (for West Wing):** New windows to be 5-chambered PVC framed double glazing (4-16-4) windows. Glazing to be non transparent. New windows shall be provided with PVC sills in the inside and coated aluminum in the outside, draining away from the windows and provided with mosquito screens. See paragraph 2.1 with requirements for new windows.
- **Doors:** Replace existing doors with new PVC doors. PVC door shall be manufactured to be used as doors (not windows), and therefore they have to be provided by the manufacturer with 3 frames (2 laterals and top). There shall be an air gap for proper ventilation. Provide the PVC doors with heavy use hinges installed by the manufacturer. The doors shall not be provided with bottom frame. Provide door stops for all doors in the contract.
- **Floors:** After removal of the existing floor tiles, provide slopes towards the floor drains (one per room) and install new non slippery ceramic floor tiles, diagonally with respect to the walls. New ceramic tiles to be of minimum size 40x40 cm. Provide matching ceramic base board tiles along the bottom of all walls.
- **Walls:** Remove existing tiles, paint and plaster. Repair any structural damages and cracks exposed after removing the plaster. Provide new leveling plaster to provide new perfectly leveled surfaces, and cover all vertical surfaces with new ceramic tiles. Minimum size of tiles to be 30x30 cm. Provide decorative tiles (friso) at intermediate and higher section of the walls. Provide metal corner beads at all corners of tiles surfaces. Edge of ceramic tiles shall not be exposed to the view.
- **Ceiling:** Repair ceiling damages and provide new gypsum board (green – rated for humidity atmospheres) over all ceiling surfaces. Support the ceiling with new galvanized metal profiles, supporting the weight of the new ceiling on the walls (not on the existing ceiling). Size the metal profiles in order to avoid any deflection on the ceiling surfaces. Provide access gates in all rooms for maintenance purposes. Provide as high as technically possible. Cover all drainage piping from floors above under the new drop ceiling. Cover ventilation system under new drop ceiling. Provide lighting fixtures recessed within the new drop ceiling.
- **Water Piping:** Remove all the water piping from the main water line in the basement. Provide new cooper of high density polypropylene piping, rated for the intended use. Do not provide hot water in the bathrooms. Design water piping in order to have sufficient pressure and flow for the correct operation of the fluxometers required for the new toilets. If there is no sufficient pressure and flow in the water line in the basement, provide the toilets with water tank made of porcelain with water saving flushing controls. Install the water piping recessed inside the new walls and behind the new ceramic tiles. Water piping shall not be exposed at any location. Provide valves as required to have a fully operational water system and to be able to isolate each room and each plumbing fixture. Provide pressure test for 48 hours at minimum of 10 bars before covering the piping within the walls.



Picture#14: Typical heavy use hinge

- **Sewage/Drainage/Vent piping:** Remove all the sewage, vent and drainage piping inside of the bathrooms under the scope of work of this project. The intent is to connect to the sewer piping in the basement and to provide all new sewage/drainage/ventilation piping from the basement to the roof. Within the renovated areas, all sewage/ventilation piping shall be installed recessed behind the walls, but they shall be provided with the necessary access points to be able to maintain every single portion of the sewage/drainage piping.
- **Floor drains:** Provide two per bathroom in the West Wing and one per bathroom in the Central Wing. Total of 14 floor drains required. Connect the piping with the existing sewage system in the basement. Provide integrated P-trap in all floor drains to eliminate bad smell.
- **Hot Water:** Not required.
- **Heating System:** Provide a complete new heating system in the renovated bathroom facilities, consisting of radiators, piping and valves. Provide new aluminum radiators, with all required valves and accessories and connect with existing hot water heating system in the building. Design as required to obtain adequate temperature in all areas. All heating piping within the renovated areas shall be recessed with the walls/ceilings.
- **Ventilation:** Provide a ventilation system in accordance with Ukrainian regulations. This is most important for the bathrooms in the Central Wing, and the teacher's toilets, which are not provided with exterior windows. The contractor shall design the ventilation system, but it is estimated that it should include:
 - o Removing the existing louvers and air ducts.
 - o Replacing with new aluminum louvers the openings over the doors of the West Wing bathrooms.
 - o Cleaning and repairing as required the existing ventilation from each bathroom to the roof of the building.
 - o Connecting all rooms in the bathrooms to the ventilation system going to the roof.
 - o Providing a forced (electric fan) air ventilation system, designed as required by Ukrainian Code.
- **Masonry Partitions:** The scope of work requires removing some existing masonry partitions and providing new partitions. This is required by the scope of work in the girls' bathrooms of the West Wing, to make the teacher's toilets larger. The contractor can choose to remove all masonry partitions and provide new ones in the bathrooms in the Central Wing. New partitions shall be made of masonry work, as thin as technically possible to allow for covering the new piping and/or wiring.
- **Layout of Girls/Teacher's Bathrooms in the West Wing:** The contractor shall modify the existing layout as indicated in the sketch in picture#16. The intent is to provide larger room for teachers.
- **Layout for Boy's Bathroom in West Wing:** The contractor shall modify the existing layout as indicated in the sketch in picture#18.
- **Layout for Boy's and Girls Bathroom in Central Wing:** No modifications are required, but the contractor can choose to demolish all internal partitions and build new internal partitions, meeting plumbing fixtures requirements for each bathroom. See sketch in picture#17.



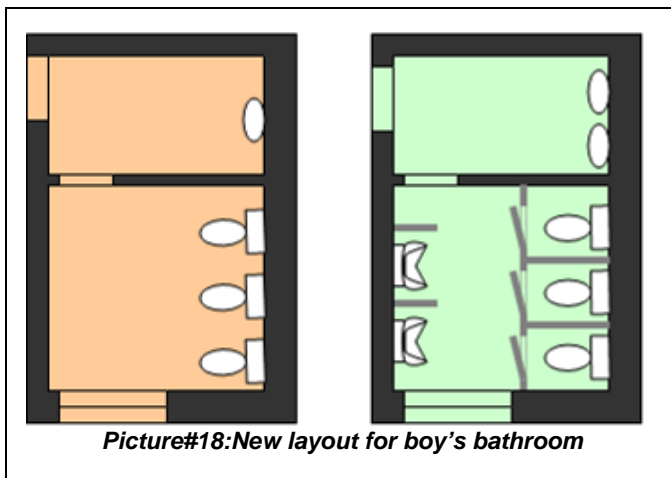
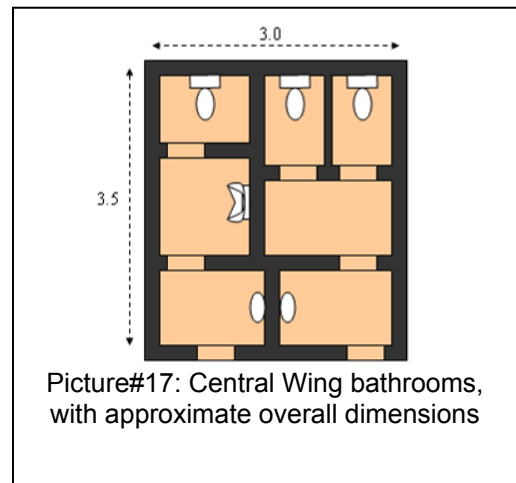
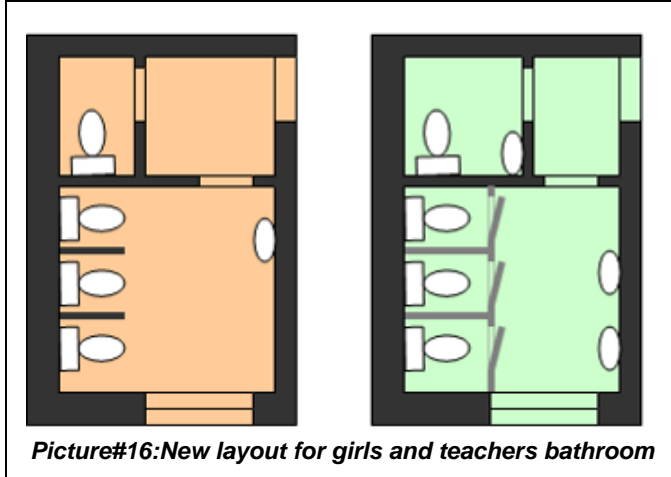

- **Electrical:** Removal and replacement of complete existing electrical system. Provide a new electrical installation connected with the main electric panel of the building (or nearby electric panel with sufficient capacity for the new electric loads). Provide a properly sized circuit breaker at the connection point to protect the electric line feeding the bathrooms. The electrical installation shall include new conduit recessed in the walls (not exposed), new junction boxes, new circuit breakers, new ground fault protection, new switches, new cables, new receptacles (in the hand washing rooms only), new lighting fixtures with energy efficient lighting and minimum protection rated IP54, and everything necessary to have a fully operational electrical system in accordance with Ukrainian Code. Provide lighting fixtures recessed within the new drop ceiling. All electrical installation be embedded in the walls, installed behind the new ceramic tiled wall.
- **Aluminum Partitions:** New toilets in the girls and boys bathrooms in the West Wing shall be made of aluminum pre-manufactured standard toilet partitions (McDonald's type). These partitions shall not touch the floor for easy cleaning of the floors (except the metal supports). They shall be provided with all required accessories, as heavy duty use hinges, door stops, locks, hangers and toilet paper holders. The 2 toilets in the girls' bathroom in the Central Wing can be separated by similar type partitions if existing masonry partitions are removed.

- **Fixtures and bathroom elements for the girls' bathrooms in the West Wing:** There are 3 girls' bathrooms to be renovated in the West Wing. Provide the following for each:
 - o 3 European Standard WC with stainless steel fluxometer (see picture#19) if there is sufficient water pressure and flow in the basement. If not, provide ceramic type water tank. Selection of the toilets shall be coordinated with the design of the aluminum toilet partitions to allow for sufficient space.
 - o Enclosed in aluminum partitions for the 3 toilets per bathroom. To be provided with locks and ample space.
 - o 2 wall mounted sinks with only cold water and automatic self closing faucets (not electric control with photocell). Drainage piping to be covered or to be made of stainless steel. No PVC drainage piping shall be exposed to the view.
 - o 2 stainless steel automatic hand driers of minimum 2 KW power (see picture#20)
 - o Soap dispensers for each sink
 - o Toilet paper holder
 - o One mirror of minimum 1.0 m², to be recessed within the new ceramic tiles and surrounded by decorative friso.

- **Fixtures and bathroom elements for the teachers' bathrooms:** There are 3 teachers' bathroom to be renovated enclosed within the girls toilets of the West Wing. Provide the following for each:
 - o 1 European Standard WC as described above.
 - o 1 wall mounted sink as described above.
 - o 1 automatic hand driers of minimum 2 KW power.
 - o Soap dispenser
 - o Hanger
 - o Toilet paper holder

- **Fixtures and bathroom elements for the boys' bathrooms in the West Wing:** There are 3 girls' bathrooms to be renovated in the West Wing. Provide the following for each:
 - o 3 European Standard WC with stainless steel fluxometer as described above.
 - o Enclosed in aluminum partitions for the 3 toilets per bathroom. To be provided with locks and ample space.
 - o 2 wall mounted urinals with pre-manufactured standard separating wall mounted partition. Drainage piping of urinals to be covered or to be made of stainless steel. No PVC drainage piping shall be exposed to the view.
 - o 2 wall mounted sinks with only cold water and self closing faucets. Drainage piping to be covered or to be made of stainless steel. No PVC drainage piping shall be exposed to the view.
 - o 2 stainless steel automatic hand driers of minimum 2 KW power
 - o Soap dispensers for each sink
 - o Toilet paper holder

- **Fixtures and bathroom elements for the girls' bathrooms in the Central Wing:** There is one girls' bathrooms to be renovated in the Central Wing. Provide the following:
 - o 2 European Standard WC with stainless steel fluxometer as described above.
 - o Enclosed in aluminum partitions for the 2 toilets per bathroom if the contractor chooses to remove the existing masonry partition. To be provided with locks and ample space.
 - o 1 wall mounted sinks with only cold water and self closing faucets. Drainage piping to be covered or to be made of stainless steel. No PVC drainage piping shall be exposed to the view.
 - o 1 stainless steel automatic hand driers of minimum 2 KW power
 - o Soap dispenser
 - o Toilet paper holder
 - o One mirror of minimum 0.5 m², to be recessed within the new ceramic tiles and surrounded by decorative friso.

- **Fixtures and bathroom elements for the boys' bathrooms in the Central Wing:** There is one boys' bathrooms to be renovated in the Central Wing. Provide the following:
 - o 1 European Standard WC with stainless steel fluxometer as described in previous page.
 - o 1 wall mounted sinks with only cold water and self closing faucets. Drainage piping to be covered or to be made of stainless steel. No PVC drainage piping shall be exposed to the view.
 - o 1 wall mounted urinal. Drainage piping to be covered or to be made of stainless steel. No PVC drainage piping shall be exposed to the view.
 - o 1 stainless steel automatic hand driers of minimum 2 KW power
 - o Soap dispenser
 - o Toilet paper holder



Picture#19: Typical toilet



Picture#20: Typical hand dryer

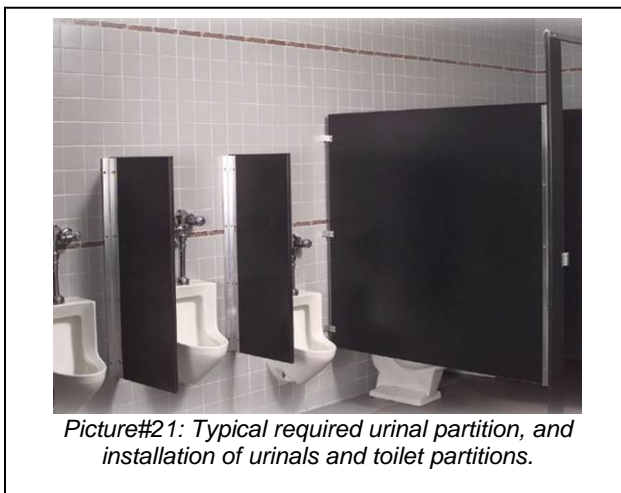

Picture#21: Typical required urinal partition, and installation of urinals and toilet partitions.



Picture#22: Provide urinals at different height and with the required partitions.



Picture#23: Typical wall supported sink



Picture#24: Typical required wall supported sink with automatic faucets for cold water



Picture#25: Sinks and mirror



Picture#26: Typical required partitions



Picture#27: Mirror with ceramic tiles friso, as required in girls' bathrooms



Picture#28: Typical aluminum with anodized finish corner protection. This is required in all corners of new ceramic tiles vertical walls.



Picture#29: Typical stainless steel corner protection for tiled corners.



Picture#30: Old bathroom converted into storage room



Picture#31: Replace ventilation system and put under new drop ceiling



Picture#32: Typical drainage piping from floor above to be replaced with new PVC piping and covered under drop ceiling and new wall surfaces. No piping to be seen in bathrooms after renovation is complete.



Picture#33: Condition of existing bathrooms



Picture#34: Typical sink in boy's bathroom of West Wing. Everything see in the pictures is to be replaced with new.



Picture#35: Typical girls' toilets in West Wing. All to be replaced with new.



Picture#36: Replace door and louver for ventilation over the doors of the 6 bathrooms in West Wing



Picture#37: Typical condition of boys' toilets in West Wing



Picture#38: All piping to be removed and replaced with new to be recessed within the new wall surfaces.



Picture#39: Old bathroom converted into storage room.

1.3.3. Repair of Gymnasium and Locker Rooms

The contract includes in its base-bid the repair of the Gymnasium and locker rooms as detailed herein. The works included in paragraph 1.3.3. and its subparagraphs pertain exclusively for the areas highlighted in orange in picture#40 below.

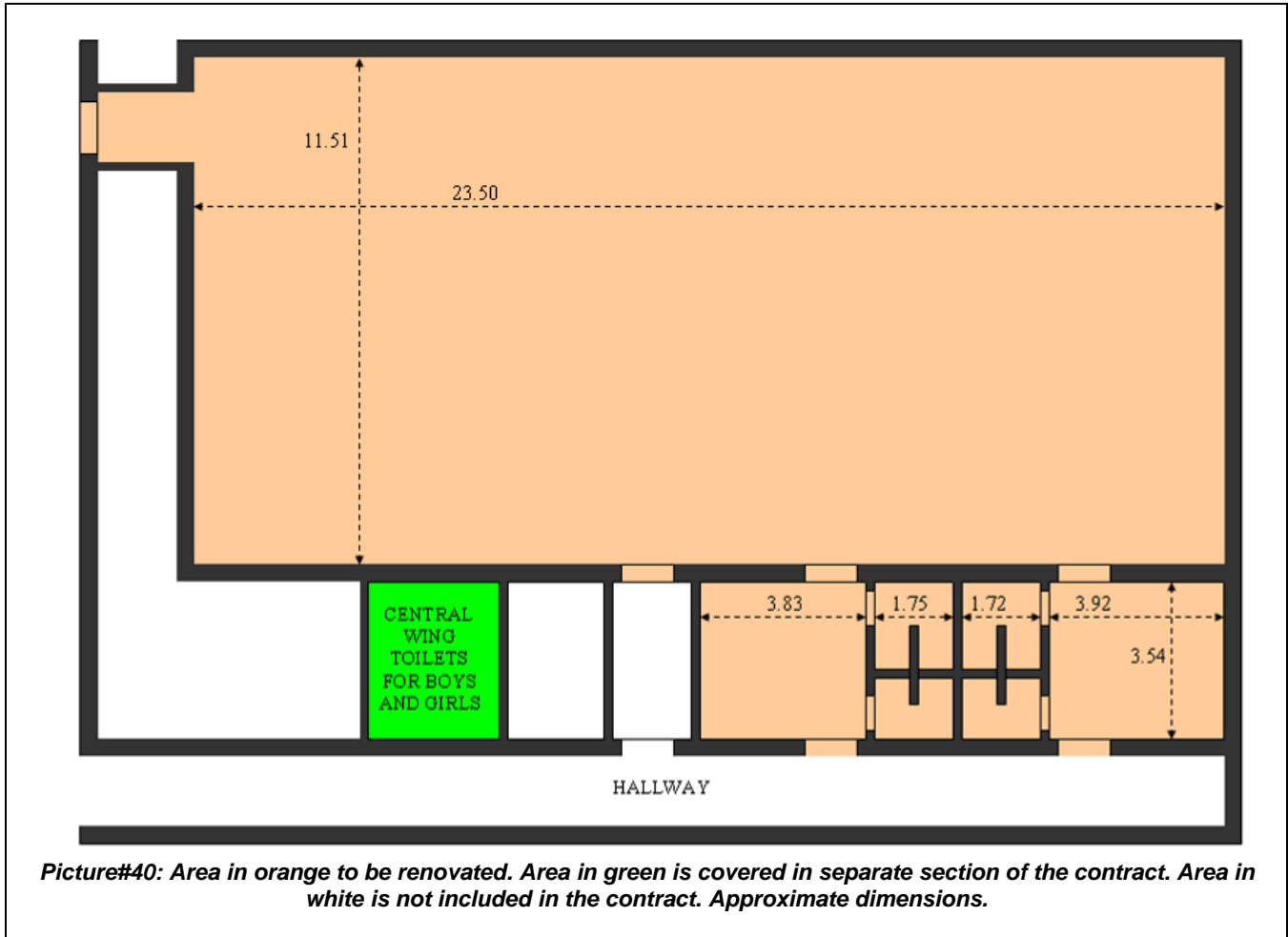

The project includes the complete renovation of the gymnasium and locker rooms located in the central wing of the school, including the locker rooms, bathrooms, showers, and main gymnasium room (see picture#40 above)

The contractor shall provide a new electrical feeder (circuit) from the main electric panel of the building or from the nearest electric panel with sufficient capacity for the intended loads. This new electric circuit shall be provided with the required electrical protection and shall be routed with channels so that the cables are not exposed to the view. The contractor shall design and install a new electric panel (wall recessed) for all the electric loads of the gymnasium area. From this new panel, the contractor will provide electric circuits to all the renovated rooms. The contractor shall provide electrical connections from the new panel to other areas of the gymnasium and the school affected by this project but not included in the scope of work of the project.

Once the project is finished, the large gymnasium and its locker rooms (with showers) will have the appearance of a completely new facility.

The work includes, but is not limited to the following:

1.3.3.1. Repairs to the Main Gymnasium Room

As described in picture#40, this area includes the main gymnasium room (approximately 11.51 x 23.50), plus the small hall connecting this area with the main entrance hall of the school. The project includes the complete renovation of the main gymnasium area, including, but not limited to:

- **Walls:** Remove paint from walls by manual or mechanical means, level and repair all surfaces and provide 3 coats of paint. In order to level the wall surfaces, new plaster will be required in some areas. In some areas the reinforcing is exposed, or the cover of metal structural members is insufficient. The exposed reinforcement shall be repaired by epoxy based mortar and the loose plaster removed and properly repaired. It must be noted that part of the heating piping and electrical conduits need to be recessed along the walls, and therefore this will require repair works along the walls. Provide new surfaces resistant to impacts. Provide washable paint (combination of 3 colors to be selected by School Director). Once the work is completed, there shall be no visual difference between the repaired and non-repaired areas. Provide wall protection in lowest 2 meters (see bullet on wall protection)
- **Ceiling:** Remove the paint by manual or mechanical means. Repair structural damages as on the walls. Level all surfaces and provide 3 coats of paint.
- **Heating:** Design and install a heating system as required for the new flooring to be installed and in coordination with the new required ventilation system (see bullet about ventilation). Remove all heating piping, radiators and wooden protection system. Provide and install new heating system connected with the building heating system. Connect heating piping with the school heating piping, at a location where the piping has sufficient capacity to provide the required heat in the room, considering the additional heat losses caused by the new required ventilation. Provide proper physical protection for the new aluminum radiators for a sports facility (see paragraph below on benches). Piping for heating system to be recessed along the walls or floors or otherwise not exposed to the view by approved shield. Heating piping shall not be seen.
- **Benches:** Provide benches to protect the heating system as shown in picture#41. The contractor shall remove all existing wood from the gymnasium and provide new benches in coordination with the protection of the new heating radiators as in picture#30. Provide along the 2 main walls. Material to be in accordance with recommendations of the manufacturer of the radiators and in accordance with Ukrainian Fire Code.
- **Electrical:** Replacement of the entire electrical installation. The contractor shall completely remove the electrical installation in this room (including lighting fixtures on the ceiling). All loads to be connected to the new electric panel described in the third paragraph of paragraph 1.3.3. The new electrical installation for the gymnasium shall be provided with new wall mounted receptacles (4 units) protected against impacts and a new lighting system. The lighting fixtures shall be halogen sports type lighting fixtures, protected against impacts, and capable of providing 500 lux at any location of the room. The lighting fixtures shall be controlled by individual switches to be located at the entrance of the room, and they shall not be controlled by the circuit breakers of the main electric panel. A minimum of 8 new lighting fixtures are required, to be installed at different locations. Control lighting by 4 different switches to be able to regulate the amount of lighting. All electrical conduits to be PVC recessed along the walls. No electrical conduit shall be exposed to the view. Provide 4 electrical wall receptacles, at the locations to be indicated by the School Director. Provide emergency exit lights.



- **External Windows:** Replace all external windows with 5 chamber PVC profile windows. 25% of the window surfaces shall be operable (horizontally and vertically). New windows shall be double glazing with minimum 4-16-4. Windows shall be provided with an internal metal net protection, properly sized, so that a tennis ball cannot go through (see picture#42). These protections shall be hinged so that they can be opened for cleaning and maintenance of the windows.

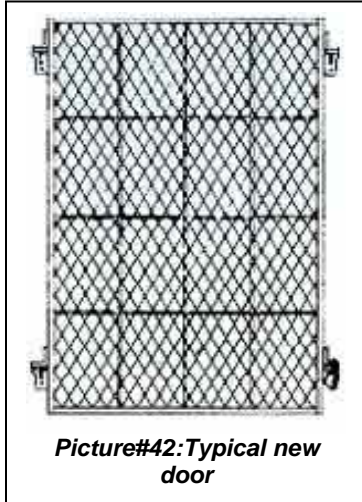

Picture#42: Typical new door



Picture#43: Typical new door



Picture#44: Provide new similar wood racks

- **Doors:** Remove the existing doors (4 units) and replace with new solid wood flush doors of similar size (see picture#43). Remove all existing wood from the door openings, including frames, anchors and trims. The doors shall be minimum 4 cm thick and provided with the required locks and hardware. Provide see through window with 8 mm glazing. Protected against impacts. This includes the door connecting the main gymnasium room with the entrance lobby of the school. Finishes in the areas not included in the contract shall be restored to original conditions after replacement of the doors (i.e. school entrance lobby). Provide doors with professional door signs in English and Ukrainian indicating:

- From main school entrance lobby to gymnasium: Gymnasium
- From hallway to gymnasium: Gymnasium
- From main gymnasium to boys locker room: Boys Locker Room
- From main gymnasium to girls locker room: Girls Locker Room



Picture#45: Typical professional door sign

- **Wood racks/volleyball support:** Replacement of “wood racks” in the gym. Remove existing wooden racks and provide new ones of similar size in the same location. Provide 2 new volleyball support poles (with one volleyball net) anchored to the walls (see picture#51)

- **Basketball boards:** Remove existing basketball boards. Provide 2 new professional basketball boards (2 units) and 4 “regular” basketball boards with rim at 3.05 m from finished floor surface. Professional basketball boards shall be installed at both ends of the gymnasium and shall be made of methacrylate backboards of 10 mm thickness (with foam protection in the bottom) properly anchored to the walls, and with break-away basketball rims (see picture #47). The “regular” basketball boards shall simpler basketball boards as shown in picture#46. All basketball rims to be installed at the official distance from finished floor elevation.



- **Wall Protection:** Provide wall wainscot in lowest 2 meters of walls. Material to be natural wood, linoleum or other similar approved material (not plastic). Material to comply with Ukrainian Fire Code. See Pic#50.

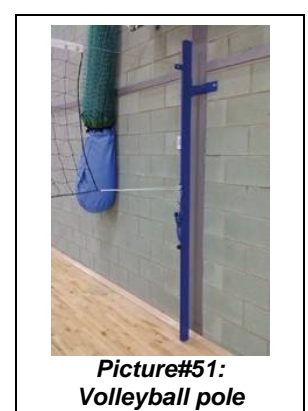

- **Floor:** New flooring surface shall be completely new. The existing flooring is in poor condition. However, its installation is apparently solid and it could be utilized as a support for the new flooring surface if preferred by the contractor. For this reason, the contractor can choose between these two alternatives:
 - Utilization of the existing flooring system as the support for the new flooring surface. If this alternative is chosen, the contractor shall correct any supporting deficiency of the new floor, and then install the new flooring system as required by the manufacturer over the existing one, but it shall include as a minimum over the existing flooring: Leveling wood with rubber shock absorbent, 2 layers of plywood of minimum thickness of 12 millimeters and a final wearing hard wood layer of 22 millimeters thickness. In this case, the floor elevation would be higher than the existing. The contractor would be responsible to make all adjustments with the adjacent areas in order to provide a solid transition between flooring surfaces with minimum trip hazards.
 - Complete removal of the existing wood flooring and its supporting structure. Installation of a new sports rated natural wood flooring surface. The contractor shall remove the existing wood flooring and support system and provide new sports rated solid natural wood flooring. Once the existing floor is removed, the contractor shall perform any modification that may be necessary to install the new flooring system (i.e. reroute heating lines or leveling). Leveling shall be done with wood, and following manufacturer's recommendations. Finished floor elevation shall be similar to the existing one to match the elevation of adjacent areas.

Flooring system shall be specifically designed to be used in indoor sport facilities, such as basketball courts, and the contractor shall show evidence of previous use of this flooring system for similar use. Finish material shall be 22mm strip made of oak, beech or similar resistance hard wood. Base shall have 2 layers of minimum 12 mm plywood, resilient polyurethane pads, vapor barrier, and required leveling wood material.

Floor shall be varnished following manufacturer's recommendations. Floor to be installed by experienced workers following manufacturer's recommendations and striped for basketball and volleyball. Hollow sound of any portion of the finished floor when bounced with a basketball shall be justification for non acceptance of the floor. Manufacturer representative shall certify surface preparation, installation and finishes before any payment is authorized for the sports rated wood flooring.

At least one of the site visit of the manufacturer technical representative shall be coordinated with the Contracting Officer Representative to meet and inspect the work together on site.

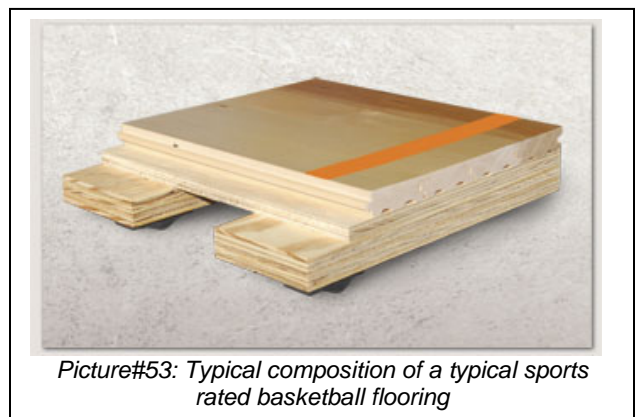
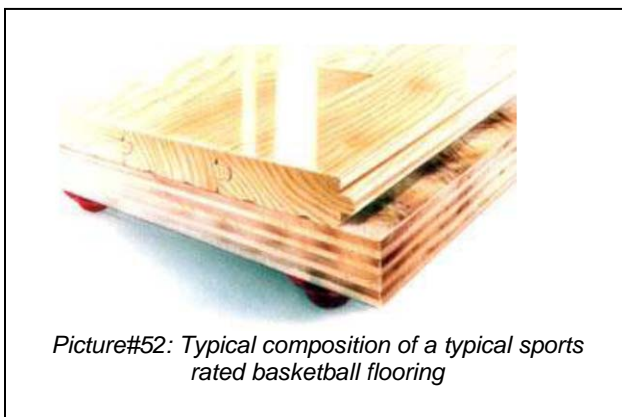



Picture#54: Required floor finishes

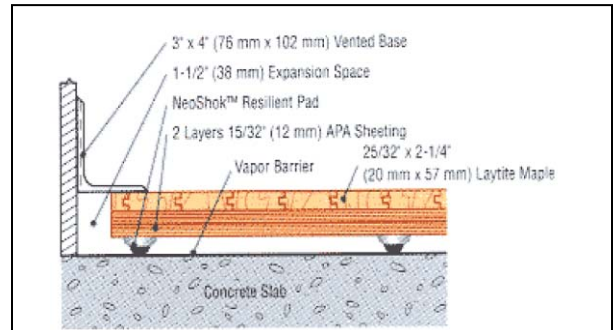

Picture#55: Typical top wood assembly

The 4 pictures above show a typical floor installation for an indoor wooden basketball court. The contractor does not need to follow these specific designs for the floor, except the thickness of the surface wood boards that shall be minimum of 22 mm and provided with tight joints (not similar to existing flooring to be removed) and other requirements described in the paragraphs above.

No payment will be authorized for any wood flooring until the manufacturer technical representative certifies the correct surface preparation and the correct installation of the new flooring.

- **Ventilation:** The gymnasium used to have ceiling openings that were covered by the school administration long ago to avoid water infiltration problems. This makes the ventilation of the gymnasium inadequate. The contract includes the design of a new ventilation system in coordination with the heating system. The work shall include the following:
 - **Exhaust:** Natural ventilation. Provide new natural ventilation as required by Ukrainian Code for gymnasiums of this type. The work includes providing sufficient opening to the outside. It is estimated that new manually operated openings will be required in the ceiling. If ceiling openings are made, these shall be provided with a metal cover in the exterior wide enough to avoid any possibility of rain/snow getting into the gymnasium. The openings shall be capable of being manually opened, closed, and fully regulated from the floor level (i.e. 10% open or 60% open)
 - **Supply:** In coordination with the exhaust, the contractor shall design and install an natural air supply system. Any existing ventilation systems to remain shall be professionally cleaned.
 - **Existing wall louvers:** There are several wall louver that shall be removed and replaced with new metal ones.
 - **Heating:** The heating capacity of the new heating system shall be properly calculated by a licensed engineer and calculations shown to the Contracting Officer for approval. Heating shall be done by new radiators connected with the school heating system. Electrical power for heating is not authorized. The contractor shall connect to the building heating system at a location with proper and sufficient capacity.



Picture#56: Door to be replaced.



Picture#57: Gymnasium room



Picture#58: Gymnasium Room



Picture#59: Basketball board and ventilation wall louvers to be replaced



Picture#60: Existing wood racks and secondary basketball board to be replaced with new.



Picture#61: Gymnasium room with door to be replaced connecting with school entrance lobby

1.3.3.2. Repairs to Locker Rooms

The project includes the complete renovation of the 2 locker rooms. Each locker room has approximately 14 m². This includes 2 separate rooms, one for boys and one for girls.

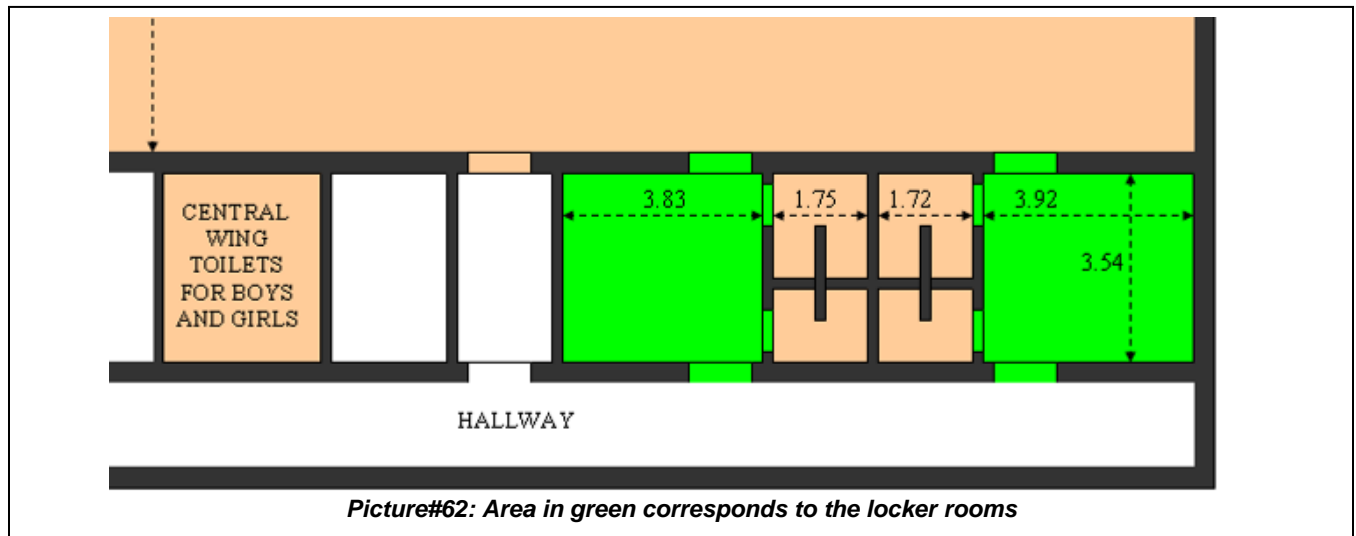

The work includes everything necessary to provide these areas with high quality and modern finishes, including, but not limited to:

- **Floors:** Remove existing floor tiles and the necessary fill material under these tiles in order to provide a new leveling layer. Provide new non-slippery gres floor tiles of minimum dimensions 40x40 cm. Install the floor tiles with joints at 45 degrees with respect to the walls (diagonally).
- **Walls:** Remove wall tiles and paint from walls by manual or mechanical means. Repair any structural damages and cracks exposed after removing the plaster. Do not use gypsum board to level the walls. Provide new leveling plaster, and cover all vertical surfaces with new ceramic tiles (from wall to new drop ceiling). Minimum size of tiles to be 30x30 cm. Provide decorative tiles (friso) at intermediate and higher section of the walls. Provide wall base in coordination with new ceramic floor tiles. Provide corner beads at all corners of tiles surfaces. Edge of ceramic tiles shall not be exposed to the view. See requirements for wall tiles for bathrooms to be renovated.
- **Ceiling:** Provide new gypsum board (green – rated for humidity atmospheres) over all ceiling surfaces. Support the ceiling with new galvanized metal profiles, supporting the weight of the new ceiling on the walls (not on the existing ceiling). Size the metal profiles in order to avoid any deflection on the ceiling surfaces. Provide access gates in all rooms for maintenance purposes. Provide lighting fixtures recessed within the new drop ceiling. Provide new drop ceiling as high as technically possible.
- **Doors:** Remove all existing doors (4 in each locker room). Provide new solid wood doors of 4 cm thickness to the hallway and to the main gymnasium area. Provide new PVC doors towards the showers as detailed in paragraph 1.3.3.3. Provide a room sign for boys and another for girls. Provide door stops.
- **Lockers:** Provide and install 15 small metal lockers in each changing room. Provide lockers with large openings for ventilation, rated for athletic use.

- **Bench:** Provide wooden benches along the walls for each changing room. Minimum length 6 meters long in each locker room. Provide with hangers to hang the clothing.
- **Heating:** Replace the entire heating system. Provide new bimetal type aluminum radiators. Replace all heating piping and provide recessed along the walls or provided with physical protection so that it is not exposed to the view. Connect with building existing heating system.
- **Ventilation:** Provide forced ventilation in accordance with Ukrainian regulations to the exterior of the building. This is very important in this room to avoid bad smell. The exhaust system shall be coordinated with the air supply, which shall be done through the doors or other means designed by the contractor.
- **Electrical:** Replacement of the entire electrical installation. Connect all electrical loads with the new electric panel provided by the contractor for the gymnasium area. The contractor shall completely remove the electrical installation in these room and provide a new lighting system. Use rapid start fluorescent lighting fixtures recessed on the new gypsum board ceiling. Lighting fixtures shall be rated for humid atmospheres. Design the lights in order to provide the minimum illumination required by Ukrainian standards. The lighting fixtures shall be controlled by 2 toggle switches for each locker room to be located at the entrances of the rooms. All electrical conduits to be PVC recessed along the walls and over the ceiling. No electrical conduit shall be exposed to the view.



Picture#63: Required benches along the walls. Picture from school#22 in Sevastopol.

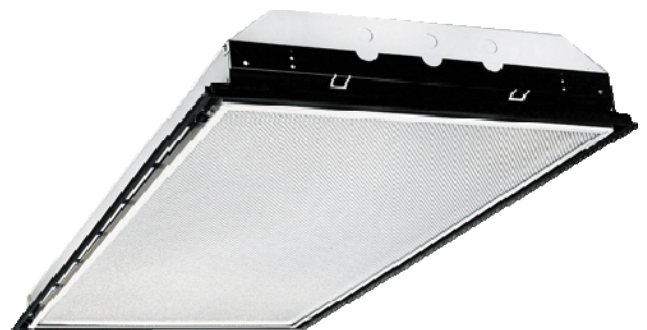

Picture#64: Typical recessed lighting fixture for the rooms with new drop ceiling



Picture#65: Interior of locker rooms



Picture#66: Interior of locker rooms. Replace radiators. Provide new ventilation to the exterior of the facility to avoid bad smell.

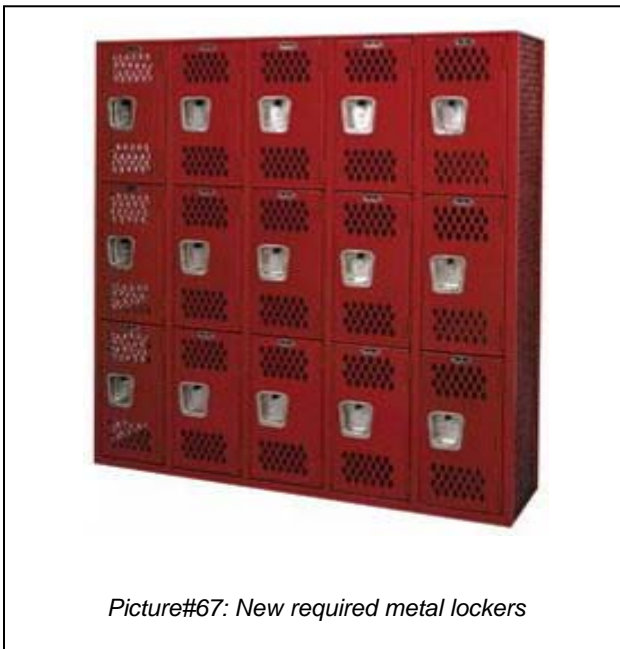

Picture#67: New required metal lockers



Picture#68: Interior of the locker room. Door to the left is the door connecting with the hallway, also to be replaced as part of this contract.

1.3.3.3. Repairs and Modifications to Showers and Toilets in Locker Rooms

The project includes the modification to the existing area as stated herein:

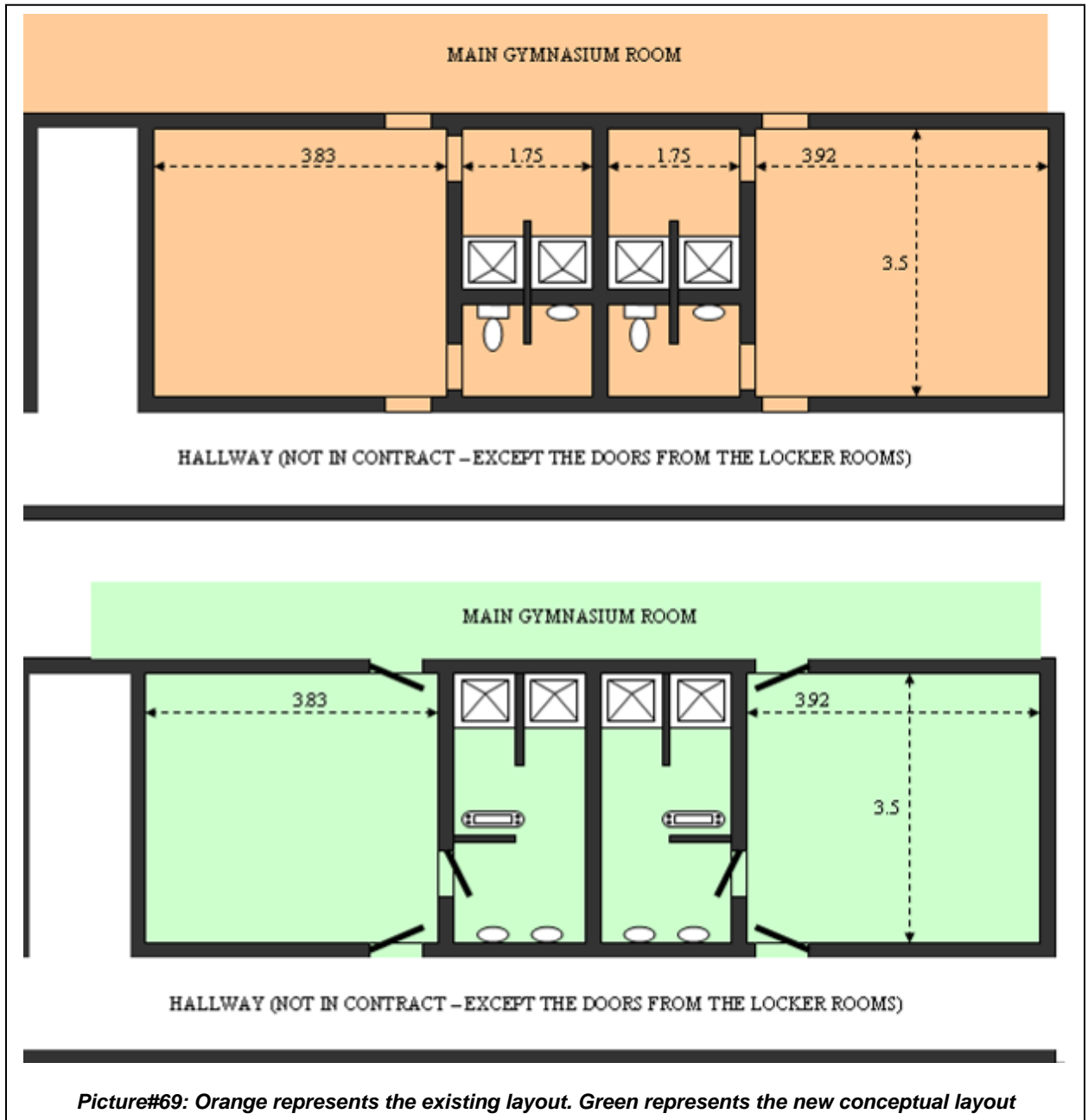

- **Layout:** Remove existing partitions and provide necessary brick partitions to build the conceptual design outlines above. The basis of design is to convert the existing spaces into a larger diaphanous area with two showers and two sinks each, providing privacy to the users. It must be noted that the toilet/sink/shower areas have not been used in a long time, and they are completely in an abandoned condition, with non operational fixtures and even with broken walls. The purpose and requirement of this project is to convert these spaces into fully modern operational areas, as outlined in the conceptual sketch shown in picture#69 above.

- **Floors:** Remove existing floor tiles and the necessary fill material under these tiles in order to provide a new leveling layer. Provide new non-slippery gres floor tiles of minimum dimensions 40x40 cm. Install the floor tiles with joints at 45 degrees with respect to the walls (diagonally). Slope all floor surfaces towards the new floor drains.
- **Walls:** Remove wall tiles and paint from walls by manual or mechanical means. Repair any structural damages and cracks exposed after removing the plaster. Do not use gypsum board to level the walls. Provide new leveling plaster, and cover all vertical surfaces with new ceramic tiles (from wall to new drop ceiling). Minimum size of tiles to be 30x30 cm. Provide decorative tiles (friso) at intermediate and higher section of the walls. Provide wall base in coordination with new ceramic floor tiles. Provide corner beads at all corners of tiles surfaces. Edge of ceramic tiles shall not be exposed to the view.
- **Ceiling:** Provide new gypsum board (green – rated for humidity atmospheres) over all ceiling surfaces. Support the ceiling with new galvanized metal profiles, supporting the weight of the new ceiling on the walls (not on the existing ceiling). Size the metal profiles in order to avoid any deflection on the ceiling surfaces. Provide access gates in all rooms for maintenance purposes. Provide new drop ceiling as high as technically possible.
- **Ventilation:** The contractor shall provide forced ventilation from the new shower rooms to the exterior of the building. The forced ventilation shall be capable of removing the air volume of the room in minimum of 3 minutes.
- **Sewage piping:** Remove and replace all the sewage and drainage piping up to the main line in the basement in accordance with Ukrainian regulations. The intent is to connect to the sewer piping in the basement and to provide all new sewage/drainage/ventilation piping from the basement to the roof. All sewage/ventilation piping shall be installed recessed behind the walls, but they shall be provided with the necessary access points to be able to maintain every single portion of the sewage piping.
- **Water Piping:** Remove all water piping. Connect the new water piping with the main water line in the basement. Provide new cooper of high density polypropylene piping, rated for the intended use for cold potable water. Install the water piping recessed inside the new walls and behind the new ceramic tiles. Water piping shall not be exposed. Provide valves as required to have a fully operational water system and to be able to isolate each room and plumbing fixture. Provide pressure test for 48 hours at minimum of 10 bars before covering the piping.
- **Hot Water:** The contractor shall reutilize the existing electric hot water heater for one of the shower rooms. Only the water heater shall be reutilized. All existing piping shall be removed and replaced with new. Provide one new hot water heater in the other shower room, with similar characteristics as the existing one.
- **Doors:** PVC doors without bottom threshold. There shall be air gap to allow for ventilation or air intake.
- **Electrical:** Replacement of the entire electrical installation. Connect all electrical loads with the new electric panel provided by the contractor for the gymnasium area. The contractor shall completely remove the electrical installation in these areas and provide a new lighting system. Use rapid start fluorescent lighting fixtures recessed on the new gypsum board ceiling rated for humid atmospheres. Lighting fixtures shall be rated for humid atmospheres. Design the lights in order to provide the minimum illumination required by Ukrainian standards. All electrical conduits to be PVC recessed along the walls and over the ceiling. No electrical conduit shall be exposed to the view. No wall receptacles shall be installed in these areas.
- **Plumbing fixtures and accessories:** The project includes the removal of all existing plumbing fixtures and accessories and their replacement with new ones as outlines in the sketches in the previous page. Provide the following in each shower room:

- **Shower:** 2 showers with curtains. Provide individual shower plates for each shower. Design to provide privacy to the users.
- **Sinks:** Similarly to the toilets to be renovated under this project, provide 2 wall hung sinks without pedestals supporting the weight on the floor (2 in each room – total of 4 units). Provide with only cold water and automatic closing faucet.
- **Toilet:** Not required
- **Floor drains:** Provide one floor drain per shower room.
- **Mirror:** Provide one in the girls shower room, recessed on the wall tiles of minimum dimension 0.5 m², surrounded by decorative ceramic friso.
- **Hand drier:** Provide one electric hand drier similar to the ones to be provided for the toilets to be renovated under this project.
- **Bench:** Provide one wooden bench in each shower room.
- **Accessories:** Provide the required soap dispenser or holder, wall hangers, and everything necessary to have a perfectly finished and operational shower room.

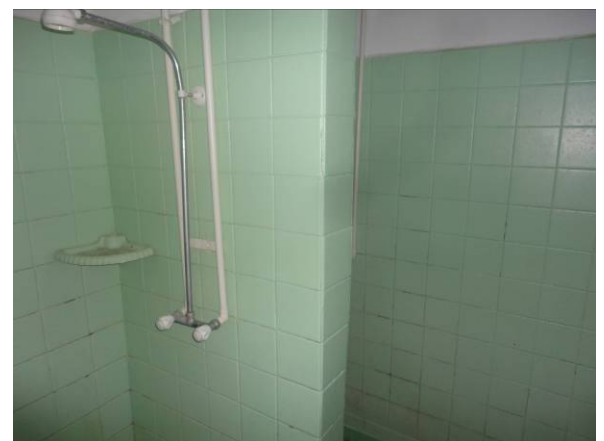
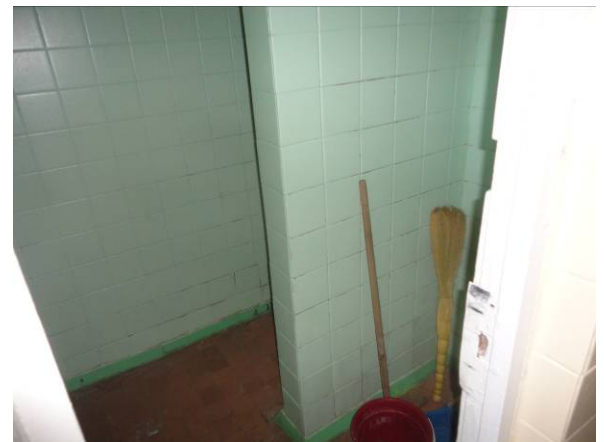

Picture#70: Existing water heater to be reutilized and supplemented with a new one.

Picture#71: Existing conditions in current shower/toilet/sink areas of the existing locker rooms. Everything to be removed, including internal partitions.

1.3.3.4. Repairs to the Hallway and School Main Entrance Lobby

The project includes only the replacement of the doors of the locker rooms (see picture #54) and the door to the main entrance lobby of the school. Remove all existing doors connecting with area under renovation in paragraph 1.3.3. and all its subparagraphs and replace with new solid wood doors. This includes 4 doors connecting with areas not to be renovated under this project. It also includes the doors of the Central Wing bathrooms covered under a different paragraph.

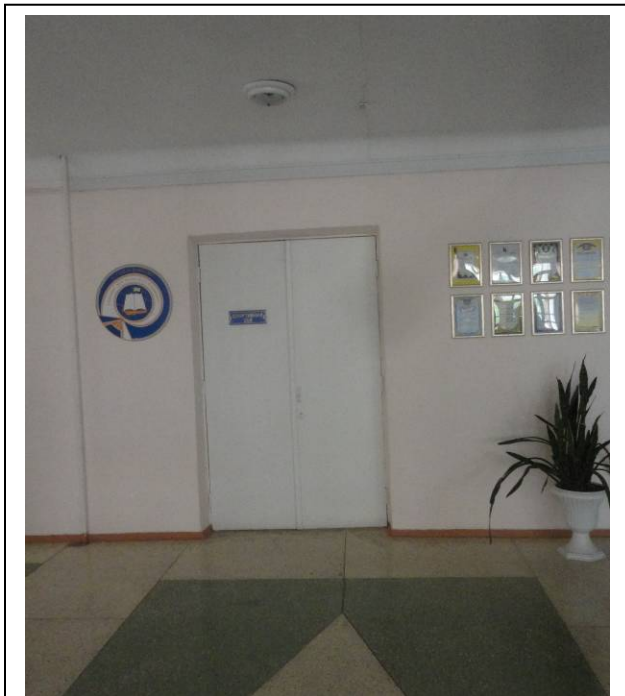

Picture#72: Gymnasium Entrance door from the main school entrance lobby. Provide new solid wood door with see through window and professional door sign. Restore all surfaces of the entrance lobby to original conditions after the door replacement.



Picture#73: Gymnasium Hallway. Replace doors to the locker rooms and restore all conditions as they were before the door replacement.

1.3.4. Commemorative Plaques (BASE BID)

The contractor shall provide and install 2 commemorative plaque at location to be indicated by the Contracting Officer. The plaques shall have the following information engraved on it:

- Colored Flag of Ukraine
 - Colored Flag of the United States of America
 - This text (or similar): “The renovation of this school was made possible through a donation from the people of the United States of America to the People of Sevastopol with the support of the Office of Defense Cooperation and US Embassy in Ukraine – Date”
 - Same text as above in Ukrainian.
- Minimum thickness 8 millimeters
 - Minimum dimensions 50 centimeters wide by 35 centimeters high.
 - Resistant to outdoor weather and UV radiation.
 - Plaque to be manufactured by specialized company.
 - One of the plaques located in the exterior shall be provided with a 1 inch methacrylate covering or other protection against vandalism.
 - Before purchasing the plaque, the contractor shall submit the design to the Contracting Officer for approval.



Picture#74: Typical similar plaque provided in a renovation project in Bulgaria



Picture#74-b: Typical similar plaque provided in School#22 Renovation in Sevastopol

1.3.5. Scaffolding – Manlifts – Harness for Fall Protection

In order to renovate the roof, or to work on the ceilings or walls, or to execute any other work from working platforms, the contractor shall be required to install scaffolding or to use manlifts.

Despite the scaffolds that may be authorized by Ukrainian regulations, the contractor is only authorized to utilize European Standard scaffolds similar to the ones shown in pictures #75 and #77. These scaffolds shall be installed and used in accordance with manufacturer's recommendations. In case the contractor needs to access the façade at any particular point without the need to install scaffolds, the contractor shall use a CE certified self-propelled man-lift, similar to the one shown in picture #78. The use of other type of scaffolds, other non CE certified man-lifts, or any type of ladders for façade or roof work, IS NOT AUTHORIZED.

Despite the requirements of Ukrainian Law for Fall Protection, any contractor employee working on the roof shall be protected with an approved harness properly tied to an approved lifeline. See pictures #76 and #79.

All other requirements of EM385-1-1 (Safety manual of US Army Corps of Engineers) and of Ukrainian Law applies for every work activity included in this project.

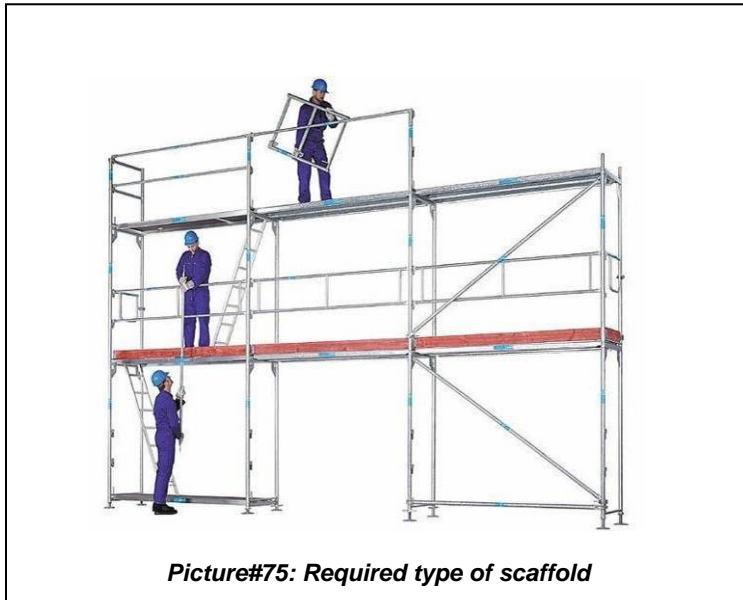

Picture#75: Required type of scaffold

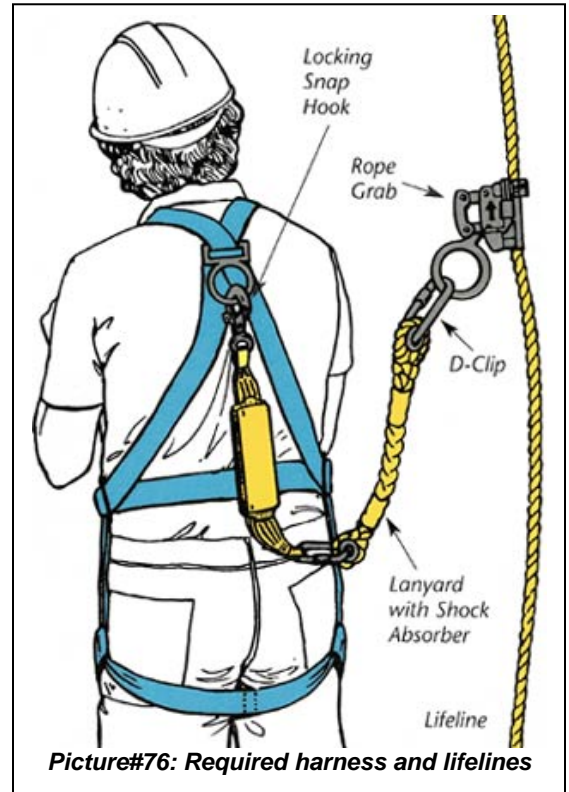

Picture#76: Required harness and lifelines



Picture#77: Required type of scaffold



Picture#78: Acceptable man-lift



Picture#79: Required harness and lifeline

DESCRIPTION OF CONTRACT OPTIONS

1.4. REPAIR OF SEWER SYSTEM (OPTION-1)

The work included in this contract option shall only be executed if, and only if, Option-1 is awarded. The scope of the project includes all necessary work, alterations and modifications to have a perfectly new sewer system in the basement of the West Wing until the point indicated in the sketch below, all in strict compliance with Ukrainian regulations. Currently the sewer lines are in very poor condition, with leaking sewer and sewer sitting on the floor of the basement.

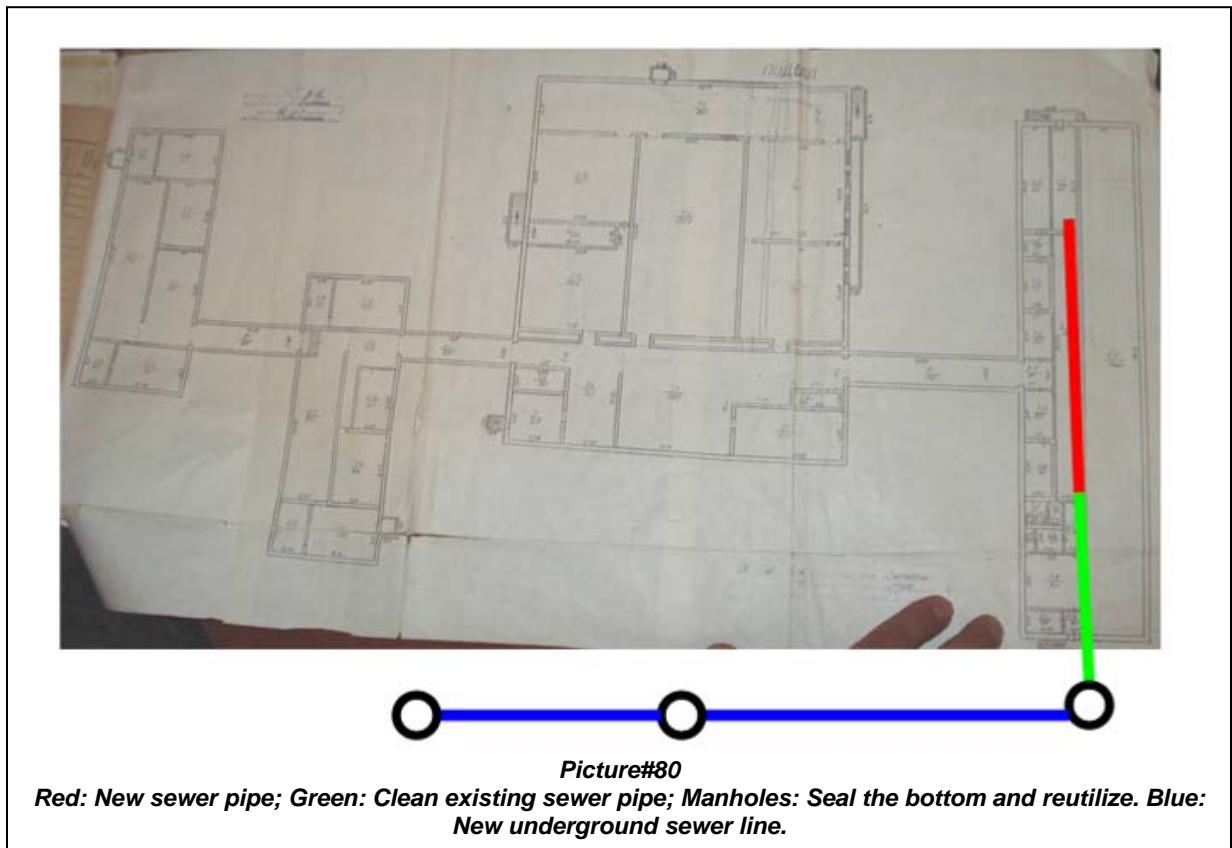

The work includes 5 different elements:

1.4.1. New Connections from basement ceiling to main sewer line

The connections from the plumbing fixtures in the West Wing to the main sewer line in the basement are corroded. They need to be removed and replaced with new PVC piping rated for gravity sewer lines. Diameter of the new piping shall be similar or greater than the existing ones to be replaced. Provide access for maintenance of the sewer lines. This corresponds to ALL the sewer connections in the basement, including where they connect with the exposed piping described in 1.4.2 and where they connect with the non-exposed piping described in 1.4.3. This includes the drainage lines from the renovated bathrooms, and other drainage lines from other areas not to be renovated as part of this contract, such as the sink in the central lobby of the West Wing or the sink in some classrooms of the West Wing. Once the work is completed, with the exception of the sewer main pipe described in 1.4.2 and 1.4.3, all sewer piping in the basement of the West Wing shall be new PVC gravity sewer lines.

1.4.2. New Gravity Sewer Line in Basement Hallway

This piping is exposed to the view along the main hallway of the basement (red colored in picture#80). The existing pipe is metal and is in general good condition. However, the joints and connections are in very bad condition. The contractor can choose to remove the pipe, clean it and reinstall with new rubber gaskets, or provide a new PVC pipe rated for gravity sewer systems of similar dimension as the existing one. The existing supports can be reutilized after they are properly repaired to allow for proper support of the existing or new pipe. If PVC pipes are chosen by the contractor, the number of supports will have to be increased to avoid any deflection of the piping. Minimum of one support for every linear meter shall be required for PVC piping.

1.4.3. Clean existing water main from the basement hallway to the exterior concrete manhole

This section of piping corresponds to where the sewer piping is not exposed to the view. It is estimated that the existing piping is in acceptable condition. For this reason, the contractor shall clean it using sewer piping high pressure water cleaning device.

1.4.4. Clean, repair and reutilize 3 exterior concrete manholes

The existing manholes are structurally sound. However the bottom of the manholes are not water proof and therefore the roots of the nearby trees have entered the manholes, creating maintenance problems. For this reason, the contractor shall clean and provide a waterproofing layer to the bottom of the manholes.

1.4.5. New exterior underground sewer pipe

The project includes the excavation, removal of existing pipe and replacement with new gravity PVC pipe rated for use in gravity sewer system, properly sloped (minimum 1% slope), backfilling the excavation and covering the excavation areas with suitable asphalt or reinforced concrete material. This include the connection piping between the 3 existing concrete manholes included in the scope of work. The contractor shall restore all surfaces to their original conditions. Once the works are completed, there shall be minimum evidence of construction activity.



Picture#81: Typical condition of sewer lines in the basement. This corresponds to paragraph 1.4.1. All piping to be replaced with new PVC piping. Provide supports as recommended by the manufacturer.



Picture#82: Central manhole to be repaired



Picture#83: Central manhole to be repaired



Picture#84: Sewer piping to be replaced (1.4.1)



Picture#85: Leaking piping to be replaced or repaired along the basement hallway (1.4.2)



Picture#86: Sewer piping to be replaced (1.4.1)



Picture#87: Connection from sewer piping to be replaced (1.4.1) to main sewer line to be repaired or replaced (1.4.2)



Picture#88: Typical lines to be replaced (1.4.1)



Picture#89: Central manhole to be repaired (1.4.4)



Picture#90: Sewer piping to be repaired or replaced (1.4.2)



Picture#91: Leaking piping to be replaced or repaired along the basement hallway (1.4.2)



Picture#92: Sewer piping along the basement hallway to be repaired or replaced (1.4.2)



Picture#93: All sewer connection piping in the basement of the West Wing to be replaced (1.4.1)

1.5. RENOVATE FRONT FAÇADE, WINDOWS, AND ENTRANCE (OPTION-2)

The work included in this contract option shall only be executed if, and only if, Option-2 is awarded. The scope of the project includes the renovation of the front façade, the replacement of windows, the repair of the entrance doors (double), the replacement of the entrance steps and the construction of an entrance ramp; all as detailed herein, and as required by Ukrainian regulations.

1.5.1 RENOVATION OF FRONT FAÇADE

The works include the complete renovation of the front façade in the areas indicated in the drawing below:



Picture#94: Area highlighted in green corresponds to the area under the scope of work of the project

The works includes the complete renovation of the front façade, to provide it with the appearance of a completely new facility. The contractor shall hire the services of an architect to provide the best and most suitable technical solution. For estimating purposes, the contractor shall estimate that the façade renovation shall require the minimum items of work:

- Removal of all ceramic tiles
- Removal of paint and loose plaster
- Removal of natural stone tiles. The contractor can choose to only replace those natural stone tiles that are cracked, broken or somehow damaged, only if after the replacement, there is no visual difference between the existing and the new natural stone tiles. Any natural stone tile to remain shall be cleaned and left with appearance of recently installed tile. Any natural stone tile shall be tapped and removed if there possibility of the tile falling in the near future.
- Providing new leveling plaster as necessary to provide perfectly leveled surfaces in those areas without tiles. All plaster to be reinforced with required synthetic net.
- Replace removed ceramic tiles with new gres ceramic tiles.

- Provide surfaces currently plastered, with new painted plaster finish. Minimum of 2 color combination to be selected by School Director.
- Provide surfaces currently covered with natural stone tiles with natural stone finish with perfectly uniform and appearance of new material.

1.5.2 REPLACEMENT OF WOODEN WINDOWS

The works include the replacement of the existing wooden windows with new PVC windows as specified in paragraph 2.1. This includes the repair of the ventilation openings for the basement.

The contract also includes providing the recently replaced windows with the same finishes as the new windows to be provided by this contract. Once the work is completed, there shall be no difference in the finishes between the existing to remain and the new windows provided under this contract. All yellow sealing foam shall be covered with plaster.

1.5.3 REPAIR OF ENTRANCE DOORS

The works include the repair of the existing double entrance doors (2 complete door assemblies, the external and the internal doors). The existing doors are old and wooden, but they are made with acceptable quality, and for that reason it is not included into the contract their replacement. However, once the repairs are completed, the doors shall have the appearance of new doors. The contractor shall perform the following minimum works:

- Remove the doors
- Take the doors to a furniture restoration or carpentry shop specialized in restoration.
- Remove the glasses
- Remove the varnish.
- Remove the accessories
- Grind all surfaces and make necessary repairs and reinforcements.
- Provide new varnish
- Reutilize the locks
- Replace the hinges with high frequency heavy duty hinges
- Reinstall all glasses and accessories
- Reinstall on site

1.5.4 REPLACEMENT OF ENTRANCE STEPS AND CONSTRUCTION OF RAMP

The works include the repair by replacement of the entrance steps and its landing area with a new one of similar dimensions, including providing a new entrance ramp with maximum slope of 8%. In order to build this, the contractor shall hire the services of an architect in coordination with the work required by paragraph 1.5.1.

The works shall include providing new steps and landing area covered by new non-slippery ceramic gres tiles. The tiles for the steps shall be specifically designed to be used in stairways. Use different pattern for vertical and horizontal pieces. The use of regular floor tiles for the steps is not authorized. See pictures below for requirements of typical tiles designed to be used in stairways. The finished elevation of the landing platform shall be the same as the elevation of the entrance lobby so that there is no tripping hazard and it can be used by people on wheelchairs.

On the landing platform the contractor shall provide a metal grid for cleaning the shoes.

The ramp shall be provided with the necessary railings. Railings shall be made of stainless steel.



Picture#95: Main entrance



Picture#96: Remove all ceramic tiles. The lower part of the natural stone tiles is painted. Paint to be removed.



Picture#97: Doors to be repaired/restored



Picture#98: Main facade



Picture#99: Steps to be repaired by replacement.



Picture#100: All ceramic tiles to be removed.



Picture#101: Typical tiles to be used for the new steps.



Picture#102: Typical tiles to be used for new steps.



Picture#103: Stainless steel railings

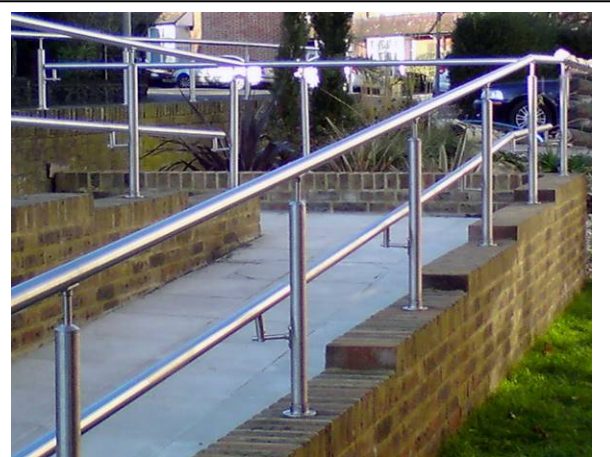

Picture#104: Stainless steel railings



Picture#105: Typical broken natural stone tile. Top piece also to be repaired. Exposed metal to be repaired or covered. Top of window opening to be repaired like rest of plastered finished surfaces.



Picture#106: Existing space that used to be used to clean shoes. Landing platform to be new at the same height as the existing.

1.6. ADDITIONAL WINDOW REPLACEMENT (OPTION-3)

The work included in this contract option shall only be executed if, and only if, Option-3 is awarded. The works included in this contract option include all the wooden windows in the area highlighted in the drawing below.

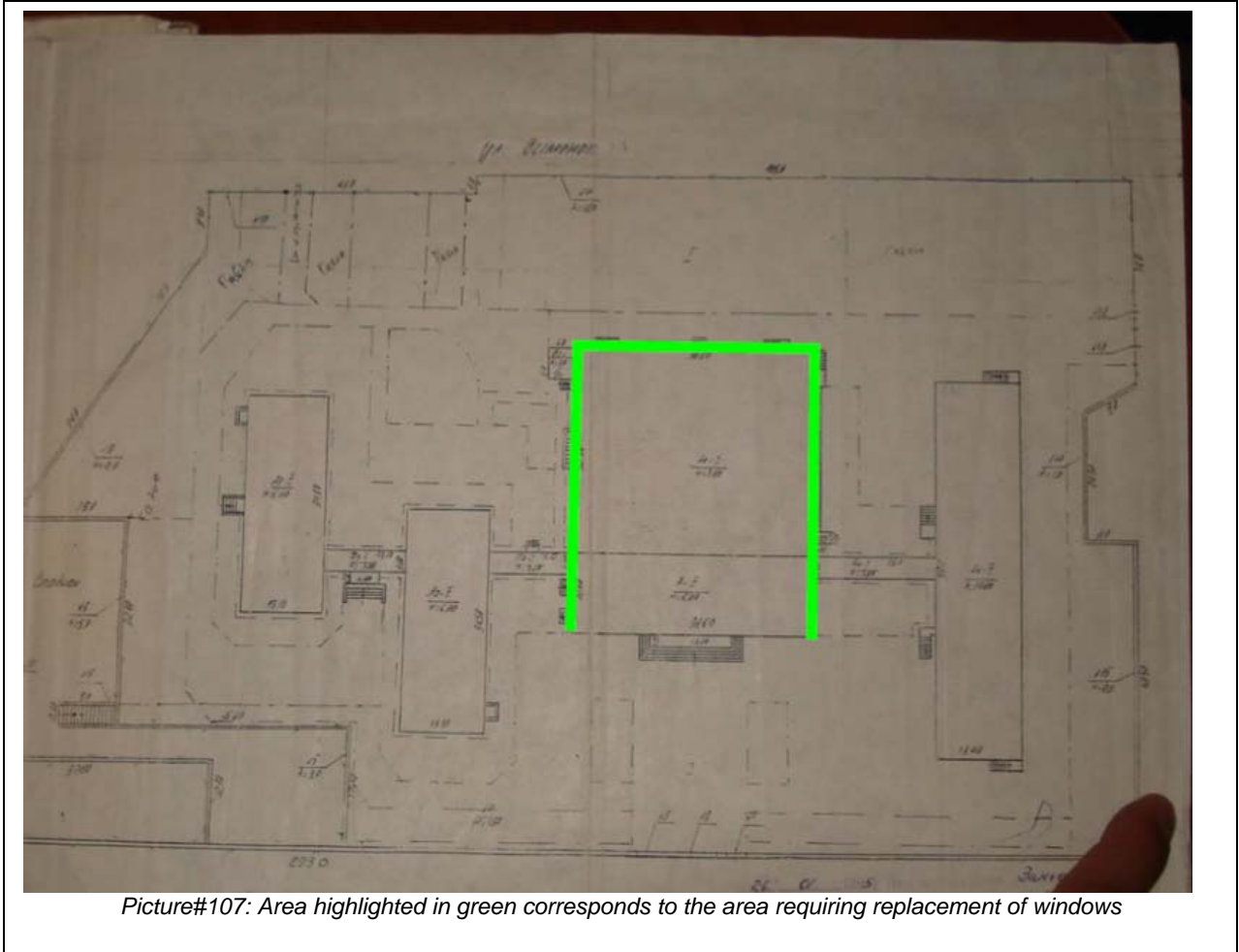

Picture#107: Area highlighted in green corresponds to the area requiring replacement of windows

The work includes replacing all the wooden windows in the Central Wing of the school. This includes the dining room, kitchen and other windows of the wing. The windows of the gymnasium and the windows of the front façade, are already included in other sections of this contract, and therefore their replacement is not part of Option-3.

The technical requirements for this item of work is included in paragraph 2.1

1.7. ADDITIONAL ROOF REPAIR (OPTION-4)

The works included in this contract option shall only be executed if, and only if, Option-4 is awarded. The works included in this contract option include the roof repair to the red highlighted areas of picture#108 below. The technical requirements to repair the roof are exactly the same as the requirements to repair the roof described in paragraph 1.3.1

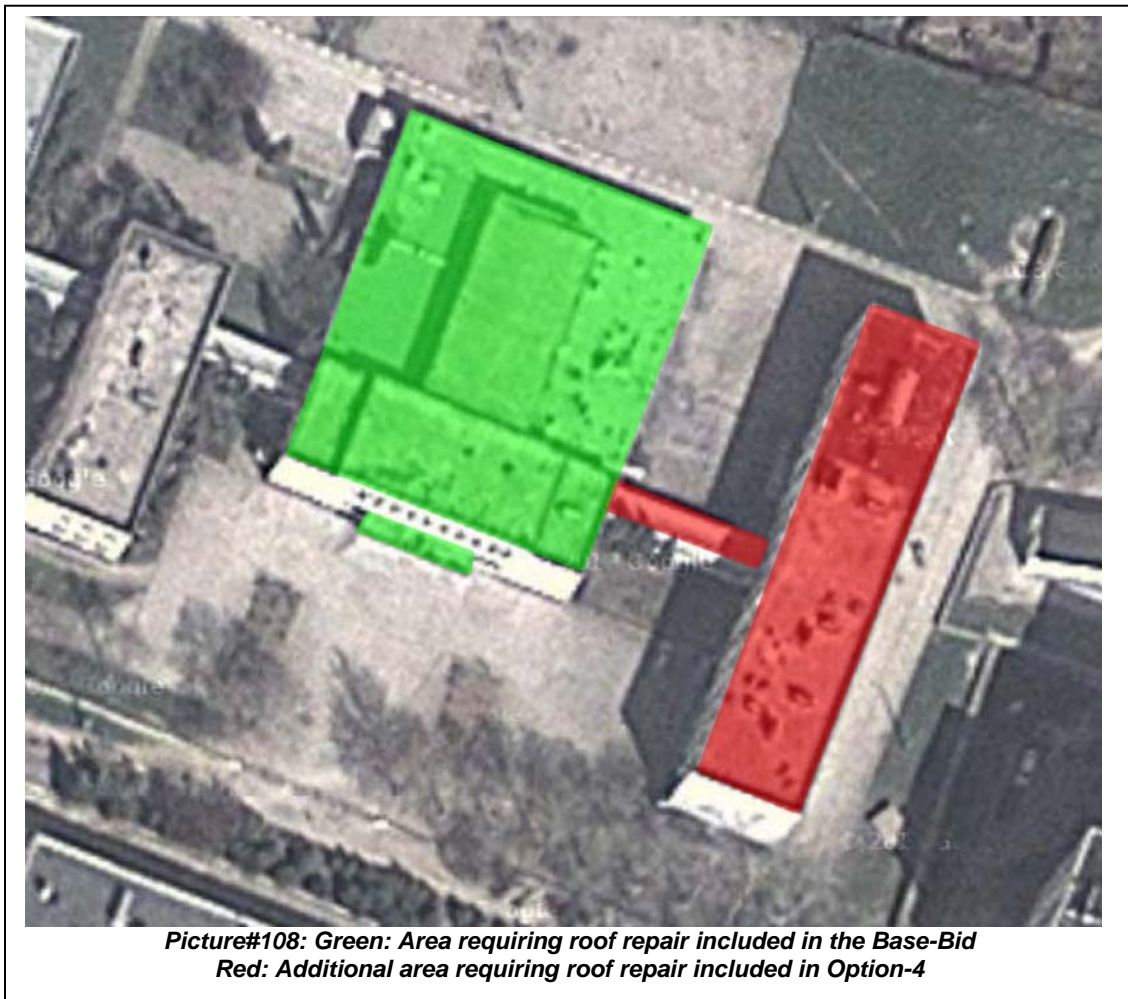

2. GENERAL TECHNICAL REQUIREMENTS

2.1. WINDOWS

The scope of work includes the replacement of some exterior windows of the of the building as indicated in the description of work. These requirements apply to all the windows that need to be replaced as part of this contract.

The contractor shall make the required adjustments and repairs to the window opening on the walls before installing the new windows. The contractor is responsible to visit the site, to take note of the existing conditions of the window openings and adjacent walls and to make all required measurements to quantify the amount of work required by this contract.

2.1.1. Exterior Windows - General

The contractor shall completely remove the indicated exterior wooden windows, including all wood framing, trims, anchors and supports. This includes windows of several sizes, that the contractor will have to quantify and measure prior to submitting their bid. The contractor shall replace the wooden windows with new PVC framed windows (minimum 5 chamber profiles) with double glazing of minimum (4-16-4).

The new windows shall operate similar as the existing ones. In other words: if a window has 2 operational panels, the new windows shall have two operational panels of approximately similar dimensions, but the opening panels/leaves of the windows shall open vertically and horizontally. For estimating purposes, the contractor shall estimate that 33% of the window surfaces shall be operational.

The new PVC windows shall be perfectly finished inside and outside. The joints between the building and the windows shall be perfectly sealed as seen in pictures below for a typical installation (typical yellow foam cannot be seen). Contractor to provide PVC sill inside as seen in the pictures below and outside sills made of aluminum or other approved material (i.e. natural marble or exterior rated special ceramic tiles).

Contractor is responsible to restore the adjacent interior and exterior wall surfaces to their original condition. The contractor shall repair, patch and paint as necessary in order to restore everything to the original conditions. There shall be no difference between the existing walls and the repaired surfaces after the installation of the new windows. For this reason, the contractor needs to inspect the existing conditions of the walls adjacent to the windows to be replaced in order to measure and quantify the amount of work required by this contract.

The operation of the new windows shall be similar to the existing windows, but the operational panels/leaves of the new windows shall open both horizontally and vertically.

Where there are security bars or grid, the windows shall be designed so that they are perfectly operational (i.e. they shall not open to the outside if there are security bars outside).

Provide aluminum insect screens in the exterior of all operational panels of the bathroom, kitchen and dining room windows. The insect screens shall be removable and shall be provided by the manufacturer providing the new windows required by this project.

2.1.2. Exterior Windows – Materials

The new windows shall be minimum of 5 chambered PVC profile with double glazing 4-16-4 (unless specified otherwise). They shall be provided with the required quality certificate in Ukraine for the intended use of the windows.

In the bathrooms, the contractor shall include non transparent glazing and mosquito nets.

Operation of the panels of the new windows shall be similar to the existing ones. Operational panels of the windows shall be designed in coordination with the security or protection bars in order to be able to open and to be cleaned.

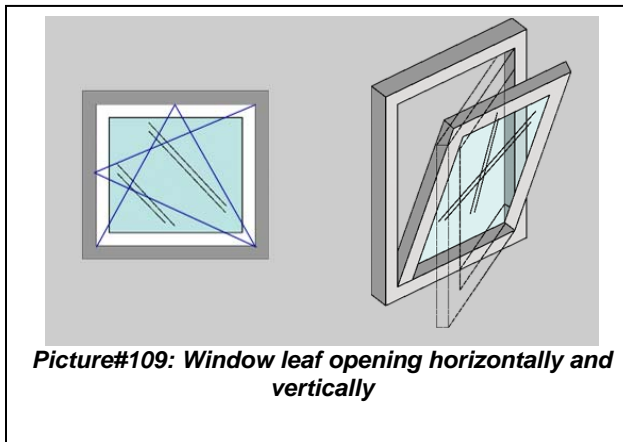

2.1.3. Exterior Windows – Installation

The contractor shall completely remove the existing wood materials from the window openings on the walls. Some of the existing windows are in general double windows, therefore the contractor shall repair and prepare the openings in the walls to install one single window with double glazing.

It is anticipated that during removal of the existing windows, the contractor will damage the adjacent walls, especially during the removal of the window sills. The contractor shall properly install the new window sills and repair the wall surfaces so that there is no difference between the existing and the repaired walls.

The exterior window sills shall be properly sloped away from the building in order to drain the rain water away from the building. The lower window frames shall be properly provided with water drains.



Picture#111: Typical exterior PVC window installation



Picture#112: Typical PVC window installation. Seal all areas around the new windows. Foam not exposed.

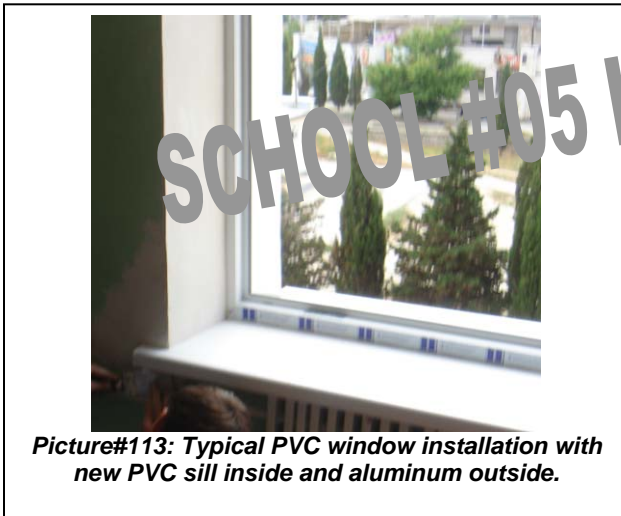

Picture#113: Typical PVC window installation with new PVC sill inside and aluminum outside.



Picture#114: Typical PVC window installation. PVC sill inside and aluminum outside.

2.1.4. Security Bars for Windows

Some of the windows in the school are currently provided with security bars of different types and designs. This project includes the removal, repair and reinstallation of the existing security bars.

The security bars shall be sandblasted, primed and painted with 2 coats of paint (color to be selected by School Director)

The contract includes any required modification to the security bars in order to properly anchor them to the wall openings for the windows. The security bars shall not be anchored to the windows, but they shall be anchored to the building structure. Anchoring metal shall be of the same size as the size of the metal in the security bars.

Once the repaired security bars are installed, they shall have the appearance of new security bars. The installation of the security bars shall comply with applicable Ukrainian regulations. **If the Ukrainian regulations require additional modifications to the security bars, such as the installation of hinges in order to open some of them, these requirements are included in the scope of work of this project.** Contractor to verify Ukrainian regulations before submitting their bids.



Picture#115: Typical security bars for windiws included in Option-3

2.1.5. Existing PVC Windows

Some of the exterior windows of the building under the scope of work of this contract have been recently replaced by the school. These windows shall not be replaced as part of this contract. However this contract includes the additional required work to make them look the same as the new ones to be provided under this contract.

The contractor shall provide proper PVC sills inside and aluminum (or other approved material) sills outside to make them have the same appearance as the rest of the new windows. The contractor shall provide proper seal around these windows, so that the “yellow” sealant foam is not exposed.

The contractor may have to remove and reinstall the entire windows to accomplish the work required by this contract, to make them have the same appearance as the new windows to be provided and install under this project.

2.1.6. Gymnasium Windows

This project includes the complete renovation of the gymnasiums. In addition to all the requirements for exterior windows, the windows in the gymnasium shall be provided with additional metal protection against the impact of balls. These protections shall be designed for the size of a tennis ball and shall be provided with hinges, so that they can be easily open to be able to clean or maintain the new windows.

2.1.7. Smaller and basement windows

The contract includes replacing all exterior windows in the areas under the scope of work of the contract, included the ventilation for the gymnasium as well as other wall openings.



Picture#116: Typical ventilation window or opening for basement

3. PROJECT OBJECTIVES

3.1 Mission Statement

The project is to improve the environment of the users of this School, and thus, improve the quality of their education.

3.2 Project Specific Priorities

3.2.1 Sustainable Principles

Integrate sustainable principles into the development and construction of the project. Reduce the total cost of ownership of the facility using a whole building, life-cycle approach.

Provide integrated sustainable principles and features to minimize the energy consumption of the facilities; conserve resources; minimize adverse effects to the environment; and improve occupant productivity, health, and comfort.

3.2.2 Energy Conservation

Integrate energy conservation principles into the development and construction of the project.

Provide energy efficient lighting fixtures.

4. PROCEDURE

This construction contract is based on 3 principles:

- Strict compliance with US contracting regulations
- Strict compliance with Ukrainian technical and legal regulations
- Strict compliance with US and Ukrainian Safety regulations

The contractor shall provide a Construction Permit from the Municipality, or the competent Ukrainian authority authorizing the works included in this contract, or a letter certifying that a Construction Permit is not required by Ukrainian Law for the scope of work of this contract.

Construction shall be in accordance with sound construction practices, and shall conform to the latest revision/edition of the codes, criteria, and standards referenced below except as otherwise indicated by this Request for Proposal. Construction shall also comply with applicable codes, ordinances and regulations of Ukraine governing life/safety, fire protection, building construction, conveying and electrical systems in effect during this contract, except where specifically stated herein. Any material installed that does not meet the requirements of this Technical Specification and/or applicable codes, ordinances and regulations will be removed and reinstalled at Contractor's expense.

4.1 Permit/Authorizations before and during construction

The contractor is responsible to coordinate, request, pay for any applicable fee and obtain the required construction permits and authorizations that are required for the works included in this construction contract as required by Ukrainian Law. No work shall commence at the job site until the contractor shows sufficient evidence that they have complied with all legal and administrative requirements of Ukrainian legislation.

The contractor shall show licenses or other verifiable evidence that they are legally authorized to perform the works described in these technical specifications in UKRAINE.

All requirements of Ukrainian legislation in order to execute this construction contract, such as declaration of works, information for commencement of works to local state administration, Fire and Technical Safety, registration of appropriate inspection declaration, obtaining the written consent of the owner of the facility, etc, are part of the construction contract.

All requirements of these Web Pages are considered an integral part of this contract. The contractor shall include in their bids the costs of carrying out all requirements of Ukrainian legislation in order to execute and manage this construction contract in strict compliance with Ukrainian legislation.

<http://zakon2.rada.gov.ua/laws/show/466-2011-n>

http://gost.at.ua/load/normativnye_dokumenty/derzhavni_buivelni_normi_dbn/12

The construction contract, by signing the award document, is thereafter delegated with the required authority and/or responsibility to obtain all required documents. The US Government remains at the disposal of the construction contractor for any assistance that could be provided, or to provide a letter with official delegation of authority. But it is the contractor's responsibility, and part of this construction contract, to obtain all required permits, authorizations and to coordinate with competent local authorities before construction and during construction.

Currently all construction projects in Ukraine are separated depending on category of complexity. Category of complexity may influence directly on the procedures of receipt of proper city planning (permitting) documents. Construction site may be attributed to appropriate category of complexity either by designer or by the Customer.

Category of complexity of construction site is determined accordingly to state norms and standards considering grade of consequences (responsibility) of such a construction site.

Grade of consequences (responsibility) of construction site is determined according to State Construction Norms of Ukraine (ДБН В.1.2-14-2009) «General principles of providing reliability and structural safeness of facilities, construction structures and foundations» according to levels of possible economic damages and (or) other losses, connecting with suspension of operation or site integrity loss.

Project documentation for facilities construction is developed in the form of procedures determined by order of Ministry of Regional Development, Construction and Housing of Ukraine dated 16.05.11 #45 («Acceptance of project documentation working out order») and also Law of Ukraine «Control of city planning activity». To provide a design of construction project Customer has to supply Prime Designer with input project data.

Input project data may consist of:

- City planning conditions and restrictions,
- Technical specification, which includes grounded requirements of the Customer to planning, architectural, engineering and technological decisions and properties of the facility, its main parameters, cost and construction arrangement and are working out with consideration of city planning conditions and restrictions and technical terms as well.

Construction Design Terms (Technical Specification) is developed and approved by Customer including acceptance of investor and Prime Designer. Approval of Construction Design Terms is implemented through signing and stamping.

Renovation Terms for working out project documentation is developed considering requirements of state construction regulations «Structure, content, order of development, acceptance and approval project documentation to renovate cultural facilities».

Both Prime Designer and Customer should determine grade of consequences (responsibilities) of construction facility and its category of complexity, on the basis of which the number of design stages is established.

Design stages:

for facilities of 1st and 2nd categories of complexity design is implemented:

- single stage – working draft stage (WDS);
- double stage – for facilities of non-production purpose – draft stage (DS), and as for facilities having production purpose and linear facilities of engineering and transport infrastructure – pre-investment feasibility study (PIFS), and for both – WDS;

for facilities of 3rd category of complexity design is implemented in two stages:

- plan stage (PS);
- working documentation stage (WDoS)

for facilities of 4th and 5th categories of complexity design is implemented in three stages:

for non-production facilities – DS, or having grounded Customer`s decision – PIFS, and as for production facilities and linear facilities of engineering and transport infrastructure – PIFS, PS, WDS.

Customer and Prime Designer may take the agreed decision as to the number of design stages. When the project is developed depending on the project category of complexity, the 4th and 5th categories of complexity are subject to compulsory expertise - keeping sanitary and epidemiological standards, ecology, labor protection, energy savings, fire, man-caused, nuclear and radiation safeness, tightness, reliability, durability of buildings and structures, its` operational safeness and engineering securing.

Construction projects of 1st and 2nd categories of complexity are not subject to obligatory expertise.

Implementation of construction works

All construction facilities according to Ukrainian regulations «Control of city planning activity» depending on complication of architectural and construction decisions and/or engineering equipping are split up into several categories of complexity

Depending on category of complexity Customer is granted the right to fulfill construction according to indicated Law in case:

- start of construction (preparatory) works notification is submitted to proper State Inspection of Architectural and Construction Control;
- start of construction (preparatory) works declaration is registered;
- construction (preparatory) permission is issued by appropriate inspection and is granted to the Customer.

To receive the construction (preparatory) permission as to construction facilities of the 1st–3rd categories, Customer is obliged to register (submit) *start of construction declaration*. Appropriation of such facilities to the 1st- 3rd categories of complexity is implemented by any project entity and construction Customer according to state construction norms and regulations considering the grade of consequences (responsibility) of such a construction facility.

Prior start of construction (preparatory) works as to construction facilities of the 4th – 5th categories of complexity, Customer is obliged to receiving *construction permission*. The order of attributing of construction facilities to the 4th and 5th categories of complexity is determined by Cabinet of Ministers of Ukraine.

The order of submission and document forms which afford a right of fulfillment construction (preparatory) works is determined by Cabinet of Ministers of Ukraine.

According to clauses of Law of Ukraine «Control of city planning activity» period of registration of declaration in an appropriate inspection is five working days, and as for construction permission – ten working days from the record date of proper statement.

Also it is necessary to mention that in case construction permission is delegated to another Customer or either change of a Prime Contractor, Contractor or persons responsible for implementation of author supervision, or responsible work executers, Customer (Client) must inform appropriate inspection regarding such changes within three days.

If *construction permission* was received by the Customer, replacement of either Customer or Prime Contractor or Contractor, Customer is obliged to re-process this permission again and such procedure wouldn't stop construction process. In case of replacement of persons responsible for

author and technical supervision, or responsible work executers Customer is obliged to informing State Inspection of Architectural and Construction Control, which issued this permission, concerning these alterations within three days from the moment of occurrence.

According to the law, Customer is responsible for fulfillment of construction (preparatory) works without providing information to appropriate inspection concerning beginning, either with non-registered declaration or without received permission from inspection.

Acceptance of operation of completed construction facilities, which may be considered as 1st and 3rd categories of complexity, and facilities construction of which were implemented under Construction Passport, is accomplished through registration of Declaration of Availability for Service which had been initially provided to the State Inspection of Architectural and Construction Control.

Acceptance of operation of completed construction facilities, which may be considered as 4th and 5th categories of complexity, is accomplished according to Availability for Service Act through providing proper certificates by State Inspection of Architectural and Construction Control.

4.2 Start of Construction

The Project Manager (PM) or Contracting Officer Representative shall authorize the start of construction. This authorization to start will not be given until the contractor:

- Provide a written evidence that they comply with all legal requirements in Ukraine in order to perform the works described in these PTS.
- Provides copy of the required permits or authorizations from the competent Ukrainian authority authorizing the execution of the works.
- Provides technical information for the proposed materials and equipment to be used for the project. Only materials and equipment previously accepted by the Contracting Officer Representative shall be brought to the job site.
- The Contracting Officer Representative accept their Accident Prevention Plan. See Annex 1 for the requirements of this Plan
- The Contracting Officer Representative accept their Quality Control Plan. See Annex 2.
- The Contracting Officer Representative accept their Construction Schedule
- Construction Sign is placed on site (see paragraph 4.10)

4.3 Scheduling Requirements / Phasing

All work shall be completed within 330 calendar days after project award.

The school shall remain in operation during the execution of the works. For that reason the contractor shall closely coordinate the construction activities with the School Director.

4.4 Construction Schedule (bar chart is authorized).

Perform all work within 330 calendar days after contract award. Within 15 days after contract award, the contractor shall provide a construction schedule including a minimum of 20 activities.

4.5 Accident Prevention Plan

SAFETY SHALL BE THE FIRST PRIORITY OF THE CONTRACTOR. SAFETY OF THE CHILDREN, WORKERS, STAFF OF THE FACILITIES, AND GENERAL PUBLIC SHALL TAKE PRECEDENCE OVER ANY OTHER FACTOR.

Within the timeframe allowed for the final design submission, the Contractor will prepare and submit an Accident Prevention Plan as required and outlined by the US Army Corps of Engineers Safety Manual (EM-385-1-1), describing procedures they plan to perform to ensure the safety of the workers, the staff of the facilities, the general public, the children and the equipment on the job site. The Plan shall clearly define the measurement that the contractor will implement to guarantee that this personnel will not be exposed to any hazards as a result of this construction contract.

Additionally, the safety plan must address types of personnel protective equipment to be used by personnel, types and frequencies of safety inspections, hazard analysis plan to prevent safety incidents, and training utilized to familiarize employees with safety policies and practices. The contractor shall comply with the US Army Corps of Engineers Safety Manual EM385-1-1 wherever the requirements of this manual are more stringent than the requirements of the Ukraine Safety Law.

No work shall start at the job site until the Accident Prevention Plan is received and accepted by the US Government representative. In Annex 1 of this document, it is included the requirements and checklist to prepare this Plan.

Ukrainian Safety Code and EM385-1-1 must be strictly followed. The contractor is responsible for the safety of the workers, the safety of the users of the facility and the general public.

4.6 Language

All communication and correspondence between the contractor and the Government personnel shall be in English. It shall be the responsibility of the Contractor to prepare proposals, invoices, shop drawings and submittals, quality control reports, computations, and all correspondence pertaining to this contract, in the English language; but the Contractor may, for his own record purposes, prepare them in the local language (Ukrainian or Russian). All correspondence to and from the Contracting Officer shall be in the English language. In case of dispute or claim, the English version will govern.

Immediately after award, the contractor shall appoint an English speaking representative, with cellular phone and e-mail address. The Contracting Officer Representative reserves the unilateral right to disapprove this person if it is found that his English language capacity is not sufficient to perform the duties required for such position.

For the visits of the Contracting Officer, the PM or their authorized representative to the job site, the contractor shall provide somebody capable of representing the construction company who can communicate in English language or the contractor shall provide a translator to translate from English to Russian/Ukrainian languages.

4.7 Submittals – Technical Information

The contractor shall provide technical information on all materials and equipment to be incorporated to the job site. This information must be sent to and accepted by the Project Manager before they are purchased by the contractor. Any material or equipment utilized at the job site that is not approved by the representative of the Contracting Officer and that if found not to comply with the requirements of this contract (or Ukrainian Legislation) shall be removed at no cost to the US Government.

4.8 Pictures

The contractor shall send weekly and representative digital pictures of their construction by e-mail once construction starts, showing construction progress. These pictures shall be used to monitor the contractor's performance and to validate the progress monthly invoices.

4.9 Quality Control Plan

Within the timeframe allowed for the final design submission, the Contractor will prepare and submit a Quality Control Plan describing personnel, procedures, tests and installation techniques that he plans to perform to ensure the quality required by these Technical Requirements and his design is obtained.

In Annex 2, it is included a guideline to prepare this Plan.

4.10 Construction Sign

Immediately after award the contractor shall prepare and install on site a construction sign with the following characteristics and information on it:

- Wood / plasticized sign with minimum dimensions 2 meters wide by 1 meter high
- Letters and logos prepared by an specialized company and designed for outdoor installation
- Flags of Ukraine and the United States of America
- The following text: THE RENOVATION OF THIS SCHOOL IS FUNDED BY THE UNITED STATES EUROPEAN COMMAND AND PROVIDED TO THE CIVILIAN COMMUNITY OF UKRAINE IN COOPERATION WITH THE SEVASTOPOL CITY ADMINISTRATION. EXECUTIVE AGENT: US EMBASSY IN UKRAINE. CUSTOMER: US NAVAL FACILITIES ENGINEERING COMMAND. PRIME CONTRACTOR: ?
- Start and completion dates.
- Same text in Ukrainian/Russian.

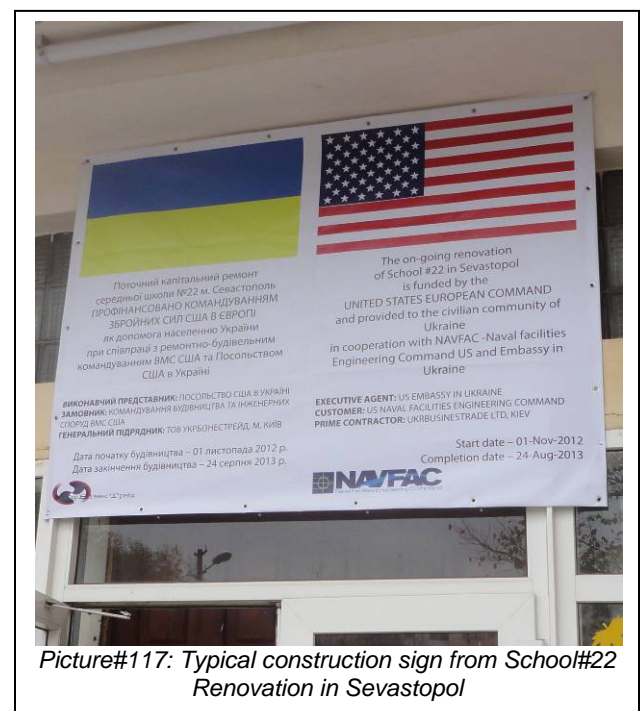

Picture#117: Typical construction sign from School#22 Renovation in Sevastopol

4.11 Payment

Payment shall be performed as required by US Administrative Requirements. See Contract Clauses pertinent to Payment procedures.

**** NO ADVANCE PAYMENT IS AUTHORIZED ****

Payment shall be performed following the principle of payment for completed work. Payment shall be phased as detailed herein:

- Partial monthly payments as agreed with the US Representative, as work is being completed and accepted
- Maximum of 80% (cumulative) is authorized until the final inspection is completed and all potential deficiencies are corrected. No payment over 80% is authorized until all work included in the contract is completed.
- Final invoice (100%) shall be paid once final inspection is completed and all potential defects identified in the final inspection are properly corrected.

Together with each invoice, the contractor shall provide:

- Official invoice
- Filled Contractor's Safety Self Evaluation Form
- Invoice Statement: With this text signed by a responsible person from the company (ideally the one that signed the contract):

I hereby certify, to the best of my knowledge and belief, that:

(1) The amounts requested are only for performance in accordance with the specifications, terms, and conditions of the contract;

(2) All payments due to subcontractors and suppliers from previous payments received under the contract have been made, and timely payments will be made from the proceeds of the payment covered by this certification, in accordance with subcontract agreements and legal requirements of the Republic of Ukraine;

(3) This request for progress payments does not include any amounts which the prime contractor intends to withhold or retain from a subcontractor or supplier in accordance with the terms and conditions of the subcontract; and

(4) This certification is not to be construed as final acceptance of a subcontractor's performance.

4.12 Occupancy of the building

The facility will remain operational during the performance of works. Daily coordination with the Director of the School will be absolutely necessary and required as part of this contract.

The facility will be occupied by staff and users of the facility (students and parents). The safety of the users of the facility, as well as the general safety of the job site, shall be the first priority of the construction contractor. **Children shall be properly separated from the construction areas by means of proper fences or barricades to be provided by the contractor.** Strict compliance with Ukrainian occupational safety and health regulations and with EM385-1-1 is required by this contract.

4.13 Payment for Utilities

The contractor is responsible to pay for any additional consumption of heat or electricity, which may be required for the execution of these works.

For electricity: They shall pay directly to the utility company

For heating: They shall pay to the agency, entity or company providing heating. Calculation shall be done proportionally and interpolating in relation with the energy consumption of the facility.

5. GENERAL WORK REQUIREMENTS

The general requirements of this specification are contained in paragraph 5. The following requirements are in addition to paragraph 5.

NOTE: This is an American document, and this note is to define the way in which numbers are presented herein:

1,000 = one thousand

3,500 = three-thousand five-hundred

1.08 = one and eight hundredths

0.1 = one-tenth

5.1 REFERENCE STANDARD

Construction shall be in accordance with sound construction practices, and shall conform to the latest revision/edition of the codes, criteria, and standards referenced herein; except as otherwise indicated by this Request for Proposal.

Construction shall also comply with applicable codes, ordinances and regulations of Ukraine governing life/safety, fire protection, building construction, conveying, HVAC (heating ventilation and air conditioning) systems, plumbing systems and electrical systems in effect during this contract, except where specifically stated herein. Any material installed that does not meet the requirements of this Technical Specification and/or applicable codes, ordinances and regulations will be removed and a new one reinstalled at Contractor's expense.

In the next paragraphs, we can find the General Work Requirements and Technical Specifications for the work requested and included in this project.

For those items required to complete the Scope of Work, which are not specified herein, the contractor shall follow the applicable Ukrainian Codes and Regulations.

5.2 CONCRETE

The work shall be performed as required by the scope of work of this project.

The construction documents for structural concrete construction shall include:

- The specified compressive strength of concrete at the stated ages or stages of construction for which each concrete element is designed
- The size and location of structural elements, reinforcement, and anchors.
- Anchorage length of reinforcement and location and length of lap splices.

5.2.1 CONCRETE MATERIALS

- 5.2.1.1 Cement shall be Portland cement approved to be used in Ukraine.
- 5.2.1.2 Locally available aggregates shall be provided in accordance with Ukrainian Code. Aggregates provided shall produce concrete of adequate strength and durability in accordance with requirements of this RFP and Ukraine Code. Nominal maximum size of aggregate shall not be larger than:
 - 1/5 the narrowest dimension between sides of forms, nor
 - 3/4 the minimum clear spacing between individual reinforcing bars or wires or bundles of bars.
- 5.2.1.3 Water used in mixing concrete shall be clean and free from injurious amounts of oils, acids, alkalis, salts, organic materials or other substances that are deleterious to concrete or steel reinforcement
- 5.2.1.4 Steel reinforcement shall be corrugated steel bars. Minimum yield (elastic) strength of 500 MPa with 12% elongation and 550 MPa tensile strength.
- 5.2.1.5 Admixtures shall be in compliance with locally approved authority having jurisdiction.
- 5.2.1.6 Use material for curing concrete.
- 5.2.1.7 Honey combing in concrete shall be repaired with approved epoxy based mortar with similar strength as the concrete used.

5.2.2 CONCRETE FORMWORK

- 5.2.2.1 Forms shall result in a final structure that conforms to the shapes, lines, and dimensions of the members as required by the design drawings and specifications.
- 5.2.2.2 Forms shall be substantially tight to prevent leakage of material.

- 5.2.2.3 Forms shall be properly braced or tied together to maintain position and shape.
- 5.2.2.4 Design of formwork shall consider: rate and method of placing concrete; construction loads – including vertical, horizontal, and impact loads.
- 5.2.2.5 Forms shall be removed in such a manner as not to impair safety and serviceability of the structure. Concrete exposed by form removal shall have sufficient strength not to be damaged by removal operation.

5.2.3 CONCRETE REINFORCEMENT

5.2.3.1 Reinforcing bars with standard hooks shall meet the following dimensional requirements:

- 180 degree bend plus 4xbar diameter extension, but not less than 65 mm
- 90 degree bend plus 12xbar diameter extension at free end of bar.

5.2.3.2 For stirrups and tie hooks:

- #16 bars and smaller, 90 degree bend plus 6xbar diameter extension at free end of bar
- #19, #22, and #25 bars, 90 degree bend plus 12xbar diameter extension at free end of bar
- #25 bar and smaller, 135 degree bend plus 6xbar diameter extension at free end of bar

5.2.3.3 Diameter of bend measured on the inside of the bar, other than for stirrups and ties in sizes #10 through #16 shall not be less than the values shown in the table below.

5.2.3.4 Inside diameter of bend for stirrups and ties shall not be less than 4xbar diameters for #16 bar and smaller. For bars larger than #16, diameter of bend shall be in accordance with table below.

Bar size	Minimum Diameter
#10 through #25	6 x bar diameters
#29, #32, #36	8 x bar diameters
#43 and #57	10 x bar diameters

5.2.3.5 All reinforcement shall be bent cold.

5.2.3.6 Reinforcement partially embedded in concrete shall not be field bent.

5.2.4 PLACING CONCRETE REINFORCEMENT

5.2.4.1 Reinforcement shall be accurately placed and adequately supported before concrete is placed and shall be secured against displacement. Vibration equipment to improve distribution of the concrete in the formwork is acceptable when used as recommended by Ukrainian Code. Concrete shall not be moved horizontally with the use of vibrators.

- 5.2.4.2 The minimum clear distance between parallel bars in a layer shall be equal to the diameter of the bar, but not less than 1 inch (25mm).
- 5.2.4.3 Where parallel reinforcement is placed in two or more layers, bars in the upper layers shall be placed directly above bars in the bottom layer with clear distance between layers not less than 1 inch (25mm).
- 5.2.4.4 In spirally reinforced or tied reinforced compression members, clear distance between longitudinal bars shall not be less than 1.5 x bar diameter nor less than 1.5 inches (38mm).
- 5.2.4.5 Clear distance limitation between bars shall apply also to the clear distance between a contact lap splice and adjacent splices or bars.
- 5.2.4.6 In walls or slabs other than concrete joist construction, primary flexural reinforcement shall not be spaced farther than three times the wall or slab thickness, or farther apart than 18 inches (455mm).
- 5.2.4.7 At the time concrete is placed, reinforcement shall be free from mud, oil, or other nonmetallic coatings that decrease bond.
- 5.2.4.8 The following minimum concrete cover shall be provided for reinforcement:
- a. Concrete cast against and permanently exposed to earth: 75 mm
 - b. Concrete exposed to earth or weather:
 - #19 bar through #57 bars 50 mm
 - #16 bars and smaller 50 mm
 - c. Concrete not exposed to weather or in contact with ground:
 - Slabs, walls, and joists:
 - #43 and #57 bars 50 mm
 - #36 bars and smaller 25 mm
 - Beams, columns:
 - Primary reinforcement, ties, stirrups, spirals 40 mm
 - Shells, folded plate members:
 - #19 bar and larger 25 mm
 - #16 bar and smaller 20 mm

5.2.5 CONCRETE MIXING

- 5.2.5.1 All concrete shall be mixed until there is a uniform distribution of materials and shall be discharged completely before mixer is recharged.
- 5.2.5.2 Job mixed concrete shall be mixed in a batch mixer approved by the locally approved authority having jurisdiction (Ukraine). The mixer shall be rotated at a speed as recommended by the manufacturer. The mixing shall be continued for at least 1-1/2 minutes after all materials are in the drum. A detailed record shall be kept to identify the number of batches produced, proportions of materials used, approximate location of final deposit in structure and the time and date of mixing and placing.

5.2.6 CONCRETE CONVEYING

Concrete shall be conveyed from mixer to place of final deposit by methods that will prevent separation or loss of materials. Conveying equipment shall be capable of providing a supply of concrete at site of placement without separation of ingredients and without interruptions sufficient to permit loss of plasticity between successive increments.

5.2.7 CONCRETE DEPOSITING

Concrete shall be deposited as nearly as practical in its final position to avoid segregation due to rehandling or flowing. Placing of concrete shall be performed at such a rate that concrete is at all times plastic and flows readily into spaces between reinforcement. Concrete that has partially hardened or been contaminated by foreign materials shall not be deposited in the structure. Retempered concrete that has been remixed after initial set shall not be used. Placing of concrete shall be continuous until placing of panel or section, as defined by its boundaries or predetermined joints is completed. Top surfaces of vertically formed lifts shall be generally level. All concrete shall be thoroughly consolidated by suitable means during placement and shall be thoroughly worked around reinforcement and embedded fixtures and into corners of forms.

5.2.8 CONCRETE CURING

Curing of concrete shall be performed in accordance with the locally approved authority having jurisdiction. At a minimum concrete shall be maintained above 10°C and in a moist condition for at least the first 7 days after placement.

5.2.9 HOT WEATHER CONCRETE

Concrete placement operations in hot weather conditions shall be performed in accordance with the locally approved authority having jurisdiction. During hot weather, proper attention shall be given to ingredients, production methods, handling, placing, protection, and curing to prevent excessive concrete temperatures or water evaporation that could impair required strength or serviceability of the member or structure.

5.2.10 COLD WEATHER CONCRETE

Concrete placement operations in cold weather conditions shall be performed in accordance with the locally approved authority having jurisdiction. Provide and maintain 10 degrees Celsius minimum concrete temperature. Do not place concrete when the ambient temperature is below 5 degrees Celsius. Cover concrete and provide with a source of heat sufficient to maintain 10 degrees Celsius minimum while curing.

5.2.11 CONCRETE TESTING

Concrete shall be tested by field technicians qualified in accordance with the Ukraine Code. Tests shall be performed on fresh concrete at the job site; prepare specimens required for curing under field conditions; prepare specimens required for testing in the laboratory, and record the temperature of the fresh concrete when preparing specimens for strength tests.

Technicians qualified in accordance with the locally approved authority having jurisdiction shall perform laboratory tests.

Sampling shall be performed at the rate required by the jurisdiction having authority. If not specified, samples for strength tests of each class of concrete placed each day shall be taken not less than once a day, nor less than once for each 115 m³ of concrete, nor less than once for each 460 m² of surface area for slabs or walls.

On a given project, if total volume of concrete is such that frequency of testing required would be less than five strength tests for a given class of concrete, tests shall be made from at least five randomly selected batches or from each batch if fewer than five batches are used.

5.3 EXTERIOR ENCLOSURE

The façade repair is included in a contract option.

5.3.1 WALL REPAIRS

The Contractor shall remove loose paint and plaster and shall repair any cracks in those areas of the façade included in the contract. Cracks shall be repaired by filling with non-shrinking grout.

5.3.2 EXTERIOR WINDOWS:

Only the existing wood windows shall be replaced. Windows shall be integral colored or co-extruded color PVC, welded and reinforced corners with reinforcing members. Use minimum of 5 chamber PVC profiles. The windows shall be operable, provided with an integral insect screen for the bathrooms and opening limiting hardware and clear double glazing (4-16-4). Window shall include the PVC frame, sills, and anchors required to secure the material in place. Follow the manufacturer's recommendation for the installation of the new windows.

Windows for bathrooms shall have non-transparent glazing.

5.4 INTERIOR CONSTRUCTION

Provide the design and installation in accordance with paragraph 5, General Performance Technical Specification. The Contractor shall provide all plant, labor, material, and equipment necessary to provide, deliver and place the interior construction as required by the contract and as specified herein.

Threshold of the new doors shall not create any tripping hazard. New doors shall have 3 frames (2 laterals and one top).

5.4.1 INTERIOR WOOD DOORS

Interior doors specified to be solid wood shall be standard solid wood as detailed in the Project Description. All interior door frames shall be wood to match the doors. Provide door hardware as required to hang, swing, lock and operate doors. Provide proper and aesthetically pleasant door thresholds for all doors in the school, providing proper transition from one type of floor to another where applicable.

Provide the design and installation in accordance with paragraph 5, General Performance Technical Specification.

The Contractor shall provide all plant, labor, material, and equipment necessary to provide, deliver and place interior finishes as required by this RFP. In particular, this section refers to the patching, painting and finishes that will be require inside of the building as a result of the SOW of this project.

5.4.2 FLOOR FINISHES

Provide floor systems as required by the description of work. Install tile systems in accordance with manufacturer's instructions. Coordinate with ceramic, linoleum, laminate and wood accessories for modularity. Include all trim pieces, caps, stops, and returns to complete installation.

Provide samples of floor manufacturer's full range of colors and styles to the School Director for selection. Floor materials shall be a minimum of one grade above manufacturer's base grade for the material complying with contract requirements described in the description of the work.

* Ceramic floor tiles: Minimum size of floor tile shall be 40 x 40 cm. Minimum of one grade over the manufacturer's base grade. Provide anti-slippery tiles. Colored grout for tile floor system shall be factory sanded Portland cement, Latex-Portland cement, or Epoxy. Provide tile joint grout sealer on white, light colored areas that are routinely exposed to water and liquid cleaning materials, entrance areas, and areas that require a high degree of stain resistance, and as required by the manufacturer.

Mortar for tile floor system shall be Portland cement, Latex-Portland cement, or Epoxy. Floor tile is to be matt finished, non-slip, fired clay mosaic tile flooring. Tile shall be placed in a mortar bed. Grout tile joints once tiles are placed and grout bed has dried. Slope tile floors at the main entrance canopy towards the outside of the building.

* Sport rated wood flooring: This floor shall be used for the gymnasium. The contractor shall remove the existing wood flooring and support system and provide new sports rated solid natural wood flooring. Once the existing floor is removed, the contractor shall perform any modification that may be necessary to install the new flooring system (i.e. reroute heating lines or leveling). Flooring system shall be specifically designed to be used in indoor sport facilities, and the contractor shall show evidence/proof of previous use of this flooring system for similar use. This floor shall be varnished following manufacturer's recommendations. Floor to be installed by experienced workers following manufacturer's recommendations and stripped for basketball and volleyball. Hollow sound of any portion of the finished floor when bounced with a basketball shall be justification for non acceptance of the floor. Manufacturer representative shall certify surface preparation, installation and finishes. No payment will be authorized for any wood flooring work if it is not certified by the

manufacturer, stating that it was installed in accordance with their recommendations, including the surface preparation.

5.4.3 Wall Base Finishes

Wall base for transition between floor and wall shall be coordinated with the adjacent flooring for color, material match and modularity.

Stone and marble wall base shall coordinate with the adjacent flooring for color, material match and modularity and shall be 4 inch (89 mm) and 3/4 inch (19 mm) thick.

Tile base shall coordinate with the adjacent ceramic wall and floor tile for color, material match and modularity. Include all pre-manufactured trim pieces, special shapes, caps, stops, and returns to provide a complete installation.

Laminate and wood flooring wall base shall be coordinated with the products used for the floors.

5.4.4 Interior Painting

Paints used on this project shall be lead free.

Painting practices shall comply with sound application and handling practices, and shall conform to the latest revision/edition of applicable codes, ordinances and regulations of Ukraine governing life/safety, fire protection and construction, in effect during this contract, except where specifically stated herein. Any material installed that does not meet the requirements of this Performance Technical Specification (PTS) and/or applicable codes, ordinances and regulations will be removed and reinstalled at Contractor's expense.

Remove dirt, splinters, loose particles, grease, oil, and other foreign matter and substances deleterious to coating performance as specified for each substrate before application of paint or surface treatments. Oil and grease shall be removed prior to mechanical cleaning. Cleaning shall be programmed so that dust and other contaminants will not fall on wet, newly painted surfaces. Exposed ferrous metals such as nail heads on or in contact with surfaces to be painted with water-thinned paints, shall be spot-primed with a suitable corrosion-inhibitive primer capable of preventing flash rusting and compatible with the coating specified for the adjacent areas.

All coats on a particular substrate, or a paint system, must be from a single manufacturer.

The surfaces of wood doors, windows, frames and trim shall receive three coats of alkyd enamel paint. Apply one coat to all surfaces of wood prior to installation and two coats to exposed surfaces after installation. Prior to applying second coat spot touch-up first coat where wood is left uncoated due to cutting, drilling or other damage as a result of installation work.

5.4.5 Plaster Finishes

New and uncoated plaster:

- One (1) coat latex filler/primer
- Two (2) coats pigmented latex paint

Existing, previously painted plaster:

Two (2) coats pigmented latex paint

New and uncoated existing plaster in toilets, food-preparation, food-serving, restrooms, laundry areas, shower areas, areas requiring a high degree of sanitation, and other high humidity areas unless otherwise specified, (Patch imperfections and fill all masonry surface voids with block filler):

One (1) coat latex filler/primer
One (1) coat pigmented alkyd paint
One (1) coat pigmented epoxy paint

Existing, previously painted plaster in toilets, food-preparation, food-serving, restrooms, laundry areas, shower areas, areas requiring a high degree of sanitation, and other high humidity areas unless otherwise specified, (Patch imperfections and fill all masonry surface voids with block filler):

One (1) coat pigmented alkyd paint
One (1) coat pigmented epoxy paint

5.4.6 INTERIOR PAINTING AND SPECIAL FINISHES

The following coatings are applied directly to all surfaces of interior construction. Paints used on this project shall be lead free.

Painting practices shall comply with sound application and handling practices, and shall conform to the latest revision/edition of applicable codes, ordinances and regulations of Ukraine governing life/safety, fire protection and construction, in effect during this contract, except where specifically stated herein. Any material installed that does not meet the requirements of this Performance Technical Specification (PTS) and/or applicable codes, ordinances and regulations will be removed and reinstalled at Contractor's expense.

Remove dirt, splinters, loose particles, grease, oil, and other foreign matter and substances deleterious to coating performance as specified for each substrate before application of paint or surface treatments. Oil and grease shall be removed prior to mechanical cleaning. Cleaning shall be programmed so that dust and other contaminants will not fall on wet, newly painted surfaces. Exposed ferrous metals such as nail heads on or in contact with surfaces to be painted with water-thinned paints, shall be spot-primed with a suitable corrosion-inhibitive primer capable of preventing flash rusting and compatible with the coating specified for the adjacent areas.

All coats on a particular substrate, or a paint system, must be from a single manufacturer.

Use 2 coats of latex, 100% acrylic emulsion (AC) with 0.0375 mm DFT.

5.5 ELECTRICAL - GENERAL

This section refers to the design and construction of the new electrical system for the gymnasium areas, the bathrooms, and other areas to be renovated under this project.

Provide design and installation in accordance with paragraph 5, Z10-*General Performance Technical Specification*.

5.5.1 Qualified Worker

Provide qualified workers in accordance with Ukrainian government criteria to perform electrical work. Qualified workers shall be allowed to be assisted by helpers on a 1 to 1 ratio, provided that such helpers are registered in a recognized apprenticeship programs. The contractor shall be able to verify with proper certification that the workers comply with Ukrainian government criteria for qualified workers.

5.5.2 Cable Installation

It is standard practice in Ukraine to use special cables directly buried in the plastered walls without any conduit (electrical cable piping). This practice IS NOT authorized by this contract. All electrical cables shall be installed inside of electrical conduits in accordance with European/US electrical standards. All electrical installation shall be recessed within the walls/ceiling/floors of the renovated areas.

5.5.3 Material Standards

Standard Products: Provide materials and equipment that are products of manufacturers regularly engaged in the production of such products which are of equal material, design and workmanship. Products shall have been in satisfactory commercial or industrial use for 2 years prior to bid opening. The 2-year period shall include applications of equipment and materials under similar circumstances and of similar size. The product shall have been on sale on the commercial market through advertisements, manufacturers' catalogs, or brochures during the 2-year period. Where two or more items of the same class of equipment are required, these items shall be products of a single manufacturer; however, the component parts of the item need not be the products of the same manufacturer unless stated in the technical section. Products having less than a 2-year field service record will be acceptable if a certified record of satisfactory field operation for not less than 6000 hours, exclusive of the manufacturers' factory or laboratory tests, is furnished. Products manufactured more than 3 years prior to date of delivery to site shall not be used, unless specified otherwise.

Ensure service support and provide manufacturer's nameplate in accordance with PTS Section Z10, *General Performance Technical Specification*.

Cables: Cables shall be rated for 0.6/1KV and the minimum size wire shall be 2.5 mm².

Conduits: The contractor shall use the existing conduits to the maximum extent possible if they are found to meet local Ukrainian Code. The contractor shall provide new conduits of

PVC to fit within the existing building. The contractor shall be responsible to conduit penetrations through walls/floors and their patching, repair and paint. No new conduits shall be exposed to the view, but they shall be recessed within the building walls and ceilings.

Provide laminated plastic nameplates for each switchboard, switchgear, panelboard, equipment enclosure, motor controller, relay, and switch. Each nameplate must identify the function and, when applicable, the position. Provide melamine plastic nameplates, 3 mm thick, white with black center core. Surface shall be matte finish. Corners shall be square. Accurately align lettering and engrave into the core. Minimum size of nameplates shall be 25mm by 65 mm. Lettering shall be a minimum of 6.35 mm high normal block style.

Factory Testing: The owner reserves the right to witness all factory testing. The manufacturer shall have a calibration program that assures that all applicable test instruments are maintained within rated accuracy.

Electric panels shall comply with the local government criteria. Provide molded case circuit breakers in accordance with the local government criteria. Provide ground fault circuit interrupting circuit breakers in accordance with the local government criteria. Provide arc fault circuit breakers in accordance with the local government criteria. Motor control centers shall comply with the local government criteria.

5.5.4 Performance Verification Testing

The Contractor shall show by demonstration in service that all circuits and devices are in operating condition. Tests shall be such that each item of control equipment will function not less than five times.

The Contractor shall provide all necessary test equipment, tools, fuel, load banks, etc., labor, and materials for testing. As a minimum, all systems shall be tested in accordance with manufacturer's recommendations. Additional testing requirements for the various systems are described with those systems, hereinafter.

The Contractor shall assure that all applicable test instruments are maintained within rated accuracy. Dated calibration labels shall be visible on all test equipment.

The following items identify specific test requirements. Additional test requirements may be required by national or local government codes or manufacturer.

Electric panels - Field test each GFI and AFI circuit breaker with a certified outlet circuit tester to verify correct operation. Provide most sensible ground fault interrupters available in Ukraine.

Motor control centers – Test motor control centers and motor starters in accordance with local government criteria.

Receptacles – Test GFI receptacles with a certified outlet circuit tester to verify correct operation.

Lighting - Verify that equipment operates in accordance with user's requirements and in accordance with manufacturer's recommendations. Measure the lighting level in each room (lux) with a proper calibrated equipment to confirm compliance with the requirements of this contract. The use of the circuit breakers as a normal way to switch on and off the lighting system is not authorized.

Grounding systems - Test the grounding system in accordance with local government criteria, but its resistance shall not be greater than 5 ohms.

Lightning protection - Upon completion of the installation, Contractor shall furnish the local government acceptance for the system.

Emergency lighting - Test emergency lighting that is intended for means of egress in accordance with local government criteria. Confirm the emergency lighting system operates for a minimum of 90 minutes and emergency illumination satisfies local government criteria specified levels.

The owner reserves the right to witness all Acceptance Tests and Inspections, review data, and request other such additional inspections and repeat tests as necessary to ensure that the system and provided services conform to the stated requirements.

Equipment shall be placed in service only after completion of required tests and evaluation of the test results have been completed.

Provide disconnecting means capable of being locked out for machines and other equipment to prevent unexpected startup or release of stored energy in accordance with the local government criteria.

Installation shall meet requirements of manufacturer's recommendations for all the equipment used, and the additional requirements for severe seismic disturbance if applicable.

6 GENERAL TECHNICAL SPECIFICATION

6.1 NARRATIVE

All Technical Specification (TS) sections must be used in conjunction with all parts of the Request for Proposal (RFP) to determine the full requirements of this solicitation. This TS section provides general requirements for the other TS sections of this RFP and is used in conjunction with the other TS sections.

6.2 CONSTRUCTION GUIDANCE

Construction shall be in accordance with sound construction practices, and shall conform to the latest revision/edition of the codes, criteria, and standards referenced below except as otherwise indicated by this Request for Proposal. Construction shall also comply with applicable codes, ordinances and regulations of Ukraine governing life/safety, fire protection, building construction, HVAC (heating ventilation and air conditioning) systems, plumbing systems, electrical systems, or sanitation systems in effect during this contract, except where specifically stated herein. Any material installed that does not meet the requirements of this Technical Specification (TS) and/or applicable codes, ordinances and regulations will be removed and reinstalled at Contractor's expense.

The contractor shall hire the services of an authorized manufacturer representative to certify the work for the wood flooring, and for any other portion of the works included in this project that may be required by applicable Ukraine Codes.

The contractor shall prepare, process and pay for all designs and technical documents and their corresponding fees that may be required by Ukrainian regulations for the works included in the scope of work of this project.

6.3 PROHIBITED ITEMS

Use of the following items in this construction project is prohibited:

- Use of aluminum for electrical conductors.
- Embedding aluminum conduit in concrete.
- Use of fluorescent light ballasts and other products containing PCB's.
- Use of urea-formaldehyde foam insulation products.
- Use of any paint/coatings having a lead content of over 0.06 percent by weight of non-volatile content. The use of ozone depleting chemicals is prohibited. The use of zinc-chromate is prohibited.
- The use of materials containing asbestos is prohibited.

6.4 RESPONSIBILITY OF MATERIALS

All materials delivered to the construction site shall remain in the ownership and responsibility of Contractor. Contractor will be responsible to safeguard the possession and condition of the material until US Government takes possession of the finalized project. Any materials or equipment stolen or disappeared from the job site before final acceptance is the responsibility of the contractor.

Material that is not intended to become part of the project shall not be delivered, placed, retained nor stored on the project site.

All refuse or salvaged materials shall become the property of the Contractor and shall be disposed of, off-site, in accordance with applicable Ukrainian regulations. The Contracting Officer may ask for receipts of proper disposal of debris, or excess materials.

6.5 SAFETY AND PROTECTION

Execution of this construction contract requires compliance with Ukrainian and USACE Safety regulations. In addition to the Accident Prevention Plan which needs to be prepared as outlined in EM385-1-1 (see Annex 1), the contractor is responsible to prepare all necessary safety documentation, studies, reports, books, design or logs, which may be required by Ukrainian regulations/legislation.

- 6.5.1 Safety of the children in the facility, safety of the workers, visitors, and general public shall be the highest priority of the contractor.
- 6.5.2 The contractor shall comply with the Safety Manual of the US Army Corps of Engineers (EM-385-1-1), wherever this US manual has more stringent safety requirements than those required by Ukrainian Code. A digital copy of this manual can be found here: http://140.194.76.129/publications/eng-manuals/em385-1-1/2008_English/toc.html.
- 6.5.3 In accordance with paragraphs 4.2 and 4.5, the contractor shall provide an accepted copy of their Accident Prevention Plan before any work is authorized to start.
- 6.5.4 The contractor is responsible for the safety of the children in the facility, the contractors employees, subcontractors, visitors and the general public, as they could be affected by this construction project. Contractor shall provide proper fences or barricades to separate the construction areas from the children and general public.
- 6.5.5 The contractor is responsible to comply with Ukrainian Safety Code. All costs of compliance with safety and with Ukrainian safety regulations are the responsibility of the contractor. Any costs related with safety inspections, safety monitoring, or anything else required to comply with the Safety regulations shall be the responsibility of the contractor.
- 6.5.6 The construction areas shall be securely separated from those areas of free access to the general public, especially to the access of the children.

- 6.5.7** Within the context of his responsibilities, the contractor shall take the necessary actions to protect the safety and health of the employees, including the prevention of occupational risks, information and training measures, and measures for the organization of the health and safety at work and its necessary means as required by Ukrainian Code. The following general prevention principles shall be taken into account for the adoption and implementation of the measures provided above:
- a. avoiding risks;
 - b. evaluating the risks which cannot be avoided;
 - c. combating the risks at the source;
 - d. adapting the work to the individual, in particular as regards the design of the workplace and the choice of work and production equipment and methods, with a view, in particular, to alleviating monotonous and repetitive work, and its effects on health;
 - e. adapting to technical progress;
 - f. replacing the dangerous by the non-dangerous;
 - g. prevention planning;
 - h. giving collective protective measures priority over individual protective measures;
 - i. giving appropriate instructions to the employees.

An employer shall insure all employees against occupational accident and disease risks, under the terms of Ukrainian law. The contractor shall verify that all employees of the prime contractor or any subcontractor employed in this project meet the legal requirements of Ukrainian Law.

The contractor shall organize the employee training in the field of health and safety at work. This training must be provided to new employees, those changing the workplace or type of work and those resuming their activity after a break longer than 6 months. In all such cases, the training shall take place before the actual beginning of the activity. The contractor shall be responsible for the facilities related to the provision of first aid in case of occupational accidents, for fire prevention and the evacuation of the employees in special situations and imminent danger.

The contractor shall be responsible for a safe and hygienic work environment both on the project site and at off-site locations where work is done in conjunction with this project.

- 6.5.8** The contractor shall be responsible for the protection of all grounds, vegetation and improvements that exist and are to remain after the project is complete; with-in the project work areas, adjacent to the project work areas and along the common route of access to the site, outside of the work areas. The Contractor shall be responsible to have any damage caused by Contractor's employees, equipment or sub-contractors repaired and restored to pre-damage condition, as approved by the PM or Contracting Officer Representative (COR), at no cost to the Government.
- 6.5.9** The Contractor shall comply with all applicable safety regulations of Ukraine, including all required record keeping.

- 6.5.10** The Contractor shall provide and maintain in working order during the entire construction period, such fire protective equipment and devices as required by applicable safety standards and as deemed necessary and suitable for any possible class or type of fires. Extinguishers shall be non-freeze type of not less than ten pound (5KG) capacity each.
- 6.5.11** Provide protection against rain, wind, or heat so as to maintain all work, materials, apparatus, and fixtures, incorporated in the work or stored on the site, free from injury or damage. At the end of the day's work, cover all new work and existing installations likely to be damaged as a result of the construction activities (i.e. roofing work).
- 6.5.12** Contractor shall acquaint themselves with the location of utilities, which may be encountered or be affected by work, and shall be responsible for damage caused by neglect to provide proper precautions or protection. If needed, the contractor shall contact any local authorities or utility companies to locate any utility service, (and pay for their services if needed).
- 6.5.13** Provide, erect and maintain all required barricades, of sufficient size and strength necessary for protection of material storage, as well as to prevent accidents to the public and the workmen at the job site.
- 6.5.14** Special precautions shall be taken to maintain the area around the facility clean for its intended service to the Community. The contractor must take into consideration that there are children in the compound, and that the compound will remain in use at all times during the renovation project.
- 6.5.15** Injuries to any person and damage to any property not belonging to the Contractor shall be reported immediately to the PM or COR (Contracting Officer Representative). Compensation to any third party affected by the construction activities (such as damage to private property) shall be the exclusive responsibility of the contractor.

6.6 CERTIFICATIONS, LICENSES, PERMITS, FEES, ETC.

The Contractor shall be responsible for determining, processing and requesting and paying all fees associated with, and obtaining any required permits for this project including, but not necessarily limited to permits for on-site and off-site hauling, demolition/disposal, construction activity, construction permits, construction monitoring, utilities, road improvements, communications, etc. The contractor is responsible for acquiring any required certifications (licensing). The Contracting Officer Representative may require at any time evidence of proper construction licensing of the contractor.

Coordinate all permit requirements with the competent local authorities or with the Contracting Officer as required. Submit all completed permit application material, and associated back-up material, required to operate facilities, to the Contracting Officer for approval prior to agency submission. Contractor shall be responsible for complying with environmental laws, regulations and requirements.

6.7 COORDINATION.

All coordination with the municipal, regional and national authorities shall be the responsibility of the contractor. The Contracting Officer shall be notified of any disputes between agencies or approvals that will affect Contract duration or Contract Price.

Coordination between the contractor and the School Director is required on a daily basis.

6.8 SPECIAL SITE CONDITIONS

Confine all operations, equipment, apparatus and storage of materials, to the immediate area of work to the greatest possible extent. Contractor shall ascertain, observe and comply with all rules and regulations in effect on the project site, including, but not limited to parking and traffic regulations, use of walks, security restrictions or hours of allowable ingress and egress.

6.9 CLEANING

Contractor shall keep premises free of accumulations of surplus materials and rubbish caused by their operations. Combustible rubbish shall be removed from the premises each day. Burning of rubbish on premises is not permitted. In addition, the Contractor shall perform final cleaning to remove all foreign matter, spots, soil and construction dust, so as to put the project in a complete and finished condition ready for acceptance and use intended.

All waste areas and storage areas will be cleaned up to the PM's satisfaction. All excess materials will be removed from the site and the Contractor will leave the premises free of debris and excess waste materials.

Daily waste shall be placed in proper containers, properly separated from children and general public.

6.10 SPARE PARTS

The contractor will provide spare parts for all new materials to be incorporated to the job site. They shall provide a total of :

- 2 lamps of each type utilized for this project,
- 5 m² or 5% of each type of flooring or ceramic tile utilized
- 20 liters of each type of paint to be used,
- and other typical materials that were used in this construction project that may be used for the user of the facility for maintenance purposes.

6.11 CLOSING THE CONTRACT

To close the contract, and to authorize final payment, the contractor shall provide:

- A copy of the letter from the contractor to the School Director or local competent authority with 1 year warranty for all the works and the special 10 year warranty for the roof. The warranty period of 1 (or 10) year starts on the day that the Contracting Officer representative accepts 100% of the work included in this contract.
- A list of spare parts provided to the facility signed by the director of the school.
- 2 books or folders containing copies of all design documents, technical information on materials and equipment used, drawing, permits and certificates used for the project. One copy to remain in the school and the other copy to be provided to the US Embassy in Kiev.

<<<END OF PERFORMANCE TECHNICAL SPECIFICATIONS>>>

Annex 1: Guideline to Prepare the Safety Plan / Accident Prevention Plan

Immediately after award, the contractor shall prepare a Safety Plan / Accident Prevention Plan following the guideline and format provided in this Annex. This is in addition to any safety plan or safety documentation that may be required by Bulgarian regulations for this type of construction activity. The Plan shall be accepted by the Contracting Officer before works are authorized to start at the job site.

NAVFAC EURAFSWA Contingency Engineering
ACCIDENT PREVENTION PLAN [APP]
Minimum Basic Outline

This first page is NOT to be included in the APP you're going to submit.

This document shall be customized in agreement to the instructions below, pages not applicable shall be removed, and the signed final document shall be submitted in pdf format.

Instructions

A. The contractor is required, at a minimum, to type-in information called for in areas denoted with a **RED arrow** and put a checkmark in the appropriate box or boxes corresponding to that section (*to check a box, double click on it, then select checked in the pop up window*). By signing this plan, the contractor is agreeing to all checked information herein and the checkmark will signify:

- a) Contractor selected one or more items from a list of items
- b) Contractor agrees with the corresponding information,
- c) Contractor agrees to follow the requirement(s) listed herein and those contained in EM 385-1-1 dated 15 September 2008
- d) Contractor agrees to develop written plans based on the requirements listed herein when required by this accident prevention plan.

B. The plan must consist of the following 10 sections:

1. Signature Sheet	6. Training
2. Background Information	7. Safety and Health Inspections
3. Statement of Safety and Health Policy	8. Accident Reporting
4. Responsibilities and Lines of Authority	9. Plans (Programs, Procedures)
5. Subcontractors and Suppliers	10. Risk Management Processes (AHA – Activity Hazard Analysis)

C. In addition to completing each section listed above several sections require certain supporting documents (resumes, certificates of training, organization chart, specific plans (crane lift plan medical support plan, etc.)). The supporting documents and plans must be attached / inserted in the appendices listed below.

Appendix	Title	Required Contents
I	Signature Sheet	As required per Section 1
II	Background Information	Area map
III	Statement of Health Policy.	Copy of signed company Safety Policy if not using generic one
IV	Responsibilities and Lines of Authority	Resume' and NAVFAC online Construction Safety Course certificate for SSHO (http://cst.wbdg.org/start.html); Proof of competency / qualification (Resumes and certificates) for persons listed in Section 4; Organization Chart (with names) for Key Corporate and Project personnel.
V	Subcontractors and Suppliers	As required per Section 5
VI	Training	As required per Section 6
VII	Safety and Health Inspection	As required per Section 7
VIII	Accident Reporting	As required per Section 8
IX	Plans	Area map showing site location; Site layout map; Acknowledgement of applicable plan key elements or NA.
X	Risk Management Processes (AHA – Activity Hazard Analysis)	AHA form for each feature of work

The reviewer of the Accident Prevention Plan shall use this checklist. The preparer of the APP shall use it to verify that all necessary information was included in the APP.

CONTRACTOR:		DATE:		
CONTRACT:		SIGNATURE:		
	A qualified reviewer shall check to assure submitted copies of the following items applicable from EM 385-1-1 Appendix A are included in the APP.	YES	NO	REMARKS
1	SIGNATURE SHEET: Plan Preparer, Approval, Concurrence.			
2	BACKGROUND INFO: Contractor, Contract #, Project Name, Brief Project Description, Contractor Accident Experience (EMR, OSHA) Corp. Trend Analysis, list of activities requiring AHA.			
3	STATEMENT OF SAFETY & HEALTH POLICY.			
4	RESPONSIBILITIES & LINES OF AUTHORITY: Identification of personnel responsible for safety (Corp. & Project Level).			
5	SUBCONTRACTOR & SUPPLIERS: Identification of Subs and Suppliers; means for controlling & coordinating; safety responsibilities.			
6	TRAINING: List subjects in safety indoctrination; mandatory training & certification, emergency response, outline requirements for supv and employee safety meetings.			
7	SAFETY & HEALTH INSPECTIONS: Identify who will conduct inspections, when & how it will be conducted & recorded, deficiency tracking sys and follow-up procedures. Any external inspections/certifications (e.g., Coast Guard etc).			
8	SAFETY & HEALTH EXPECTATIONS, INCENTIVE PROGRAMS AND COMPLIANCE: Company's written safety program goals, objectives, and accident experience goals; description of company's safety incentive program; policy/procedures for non-compliance with safety requirements; written company procedures for holding mgr. /supvs accountable for safety.			
9	ACCIDENT REPORTING: Identify person who completes the following, how, and when; exposure data (m/hrs worked); accident investigations, reports & logs; immediate notification of major accidents.			
10	MEDICAL SUPPORT: Outline on-site medical support and off-site medical arrangements.			
11	PERSONAL PROTECTIVE EQUIPMENT: Outline procedures (who, when, how) for conducting hazard assessments & written certifications for use of personal protective equipment.			
12	PLANS (PROGRAMS, PROCEDURES) REQUIRED BY THE SAFETY MANUAL: a) Hazard Communication; b) emergency response plans; c) layout plans; d) respiratory protection plan; e) health hazard control program; f) lead/asbestos abatement plan; g) abrasive blasting; h) confined space; i.e.) hazardous energy control plan; j) critical lift procedures; k) contingency plan for severe weather; l) access/haul road plan; m) demolition plan (engineering and asbestos surveys); n) compressed air plan; o) formwork and shoring erection and removal plans; p) lift slab plans; q) SHP/SSHP (for HTRW work); r) diving plan; s) alcohol drug abuse prevention plan; t) fall protection plan.			a) k) b) l) c) m) d) n) e) o) f) p) g) q) h) r) l) s) j) t)
13	Information on how the contractor will meet the requirements of the major sections of EM 385-1-1 in the accident prevention plan. Particular attention shall be paid to a) excavations; b) scaffolding; c) medical/first aid requirements; d) sanitation; e) PPE; f) fire prevention; g) machinery and mechanized equipment; h) electrical safety; l) chemical, physical agent, and biological occupational exposure prevention requirements. Detailed site specific hazards and controls shall be provided in the activity hazard analysis for each phase of the operation. A list of anticipated AHAs should be submitted with the APP.			a) b) c) d) e) f) g) h) i.e.)
14	Plans for maintaining job cleanup and safe access			
15	Public safety requirements (e.g., fencing, signs)			

ACCIDENT PREVENTION PLAN [APP]

Contract No.: **N33191-XX-X-XXXX**

Project Name:

Location:

1. SIGNATURE SHEET

a. Plan preparer (Safety manager, site safety and health officer (SSHO), or quality control representative will fill this role).

Name:	Title:
Phone no.:	Date:
Signature:	

b. Plan approval (Company owner or Company / corporate officer authorized to obligate the company).

Name:	Title:
Phone no.:	Date:
Signature:	

c. Plan concurrence (e.g., Chief of Operations, Corporate Chief of Safety, Corporate Industrial Hygienist, project manager or superintendent, project safety professional, project QC).

Name:	Title:
Phone no.:	Date:
Signature:	

2. BACKGROUND INFORMATION

Prime Contractor:
Project name:
Contract no.:



a. Project description and location. Prime contractor will provide a brief description of the project to include its location.



--

b. A map of the project site general location and site plan – Insert in Appendix IX.

c. Prime contractor accident experience. Prime contractor will provide accident experience information, if available, on how many accidents he or she has experienced in the last two years and what type of accidents have occurred.



--

d. Phases of work / Definable Features of Work. (Examples: Grading, excavation, formwork & shoring, steel erection, etc). NOTE: Section 10 requires an AHA for each of these phases

Mobilization / General Construction Demolition Scaffolding / Fall Protection Excavation / Trenching Electrical

3. STATEMENT OF SAFETY AND HEALTH POLICY

3. **STATEMENT OF SAFETY AND HEALTH POLICY.** Prime contractor will provide a safe and healthful project site which is free from recognized and anticipated hazards that could cause injury or death. The prime contractor and his subcontractor(s) and supplier(s), and visitor(s), will comply with the policies set forth in EM 385-1-1 'Safety and Health Requirements Manual' dated 15 September 2008. Include a copy of Company's Safety Policy at Appendix III.

4. RESPONSIBILITIES AND LINES OF AUTHORITY

a. **Resumes.** Prime contractor will provide resumes for safety and industrial hygiene personnel if the contract requires these positions. Competent person qualifications for the Site Safety and Health Officer (SSHO) will also be provided. At a minimum, the SSHO will have completed the OSHA 30 hour training and have one year experience. Provide training certificates for all designated competent personnel at Appendix IV.

b. **Accountability for personnel responsible for safety.**

Company owner will:

- Accept responsibility and accountability for the safety program.
- Provide leadership and guidance to supervisory personnel for the acceptance, maintenance, and enforcement of the safety program.
- Provide the necessary resources to maintain a safe and healthful project site.
- Conduct or attend monthly supervisory safety meetings.



Company owner name/phone no.

Project manager (superintendent) will:

- Implement the safety and health program at the project site.
- Conduct periodic project site inspections to verify accident prevention plan (APP) and EM 385-1-1 compliance.
- Review and act upon site safety and health inspection reports.
- Prepare man-hour reports, if applicable.
- Have authority to make spot corrections or stop work for safety purposes.
- Conduct or attend monthly supervisory safety meetings.
- Generate and/or sign ENG Form 3394 when required.



Project manager name/phone no.

Safety manager will:

- Accept administrative and oversight responsibility for the project site safety program.
- Provide technical guidance and support to the project manager, SSHO, supervisors, and foremen on safety and health issues.
- Conduct periodic worksite visits to verify APP and EM 385-1-1 compliance.
- Report observations and findings to the company owner.
- Purchase personal protective equipment (PPE) and safety supplies as necessary.
- Have authority to make spot corrections or stop work for safety purposes.
- Conduct or attend monthly supervisory safety meetings.
- Generate and/or sign ENG Form 3394 when required.



Safety manager name/phone no.

Site safety and health officer will:

- Be on site at all times when work is performed.
- Conduct frequent worksite inspections to verify APP and EM 385-1-1 compliance.
- Conduct or supervise on-site safety training.
- Investigate accidents and incidents as necessary.
- Purchase PPE and safety supplies as necessary.
- Have authority to make spot corrections or stop work for safety purposes.
- Conduct weekly employee safety meetings and attend monthly supervisory safety meetings.

- Generate and/or sign ENG Form 3394 when required.

Site safety and health officer name/phone no.



Supervisors (foremen) will:

- Cover appropriate activity hazard analysis before work begins.
- Conduct periodic project site inspections to verify APP and EM 385-1-1 compliance.
- Assist SSHO with accident and incident investigations.
- Have authority to make spot corrections or stop work for safety purposes.
- Conduct daily safety meetings with specific work crews.
- Conduct weekly employee safety meetings and attend monthly supervisory safety meetings.
- Generate and/or sign ENG Form 3394.

Workers will:

- Wear required PPE for each task.
- Inspect electrical cords daily before use.
- Inspect in-use hand and power tools daily before work begins. Guards will NOT be removed from tools equipped with guards.
- Inspect in-use machinery and mechanized equipment daily before work begins.
- Maintain good housekeeping at the worksite.
- Report accidents and incidents immediately to supervisor.
- Have authority to make spot corrections or stop work for safety purposes.
- Attend employee safety meetings.

c. **Lines of authority.** Prime contractor lines of authority will be as follows: Company owner, project manager, safety manager, SSHO, supervisors, and workers.

- Company goal.** Prime contractor will provide a safe and healthful worksite that is free from recognized or anticipated hazards that could cause serious injury or death. We will strive for a zero accident rate and demand zero tolerance for unsafe acts, the workers who perpetrate them, and persons in positions of leadership who condone such actions.
- Incentive program.** Prime contractor will provide their incentive program, if any.
- Check the box if prime contractor will provide his own non-compliance program. If not, prime will put a check mark in paragraph's d and e.**
- Worker non-compliance with safety requirements.** The commission of unsafe acts will not be tolerated at the project site. In the event this type behavior occurs the following disciplinary actions will be taken:
 - **First offense.** The offending party will be verbally warned and asked to correct the unsafe act (mentoring will take place if necessary - action will be noted in the daily report).
 - **Second offense.** The offending party will be issued a written reprimand (action will be noted in the daily report).
 - **Third offense.** The offending party will be removed from the worksite (action will be noted in the daily report).
- Supervisor non-compliance with safety requirements.** The condoning of unsafe acts at the worksite will not be tolerated. In the event this type behavior occurs the prime contractor will ensure disciplinary actions commensurate with the violation are taken.

5. SUBCONTRACTORS AND SUPPLIERS



a. Check the box if there aren't any subcontractors or suppliers working the site. If subcontractors will be onsite please identify them below, if not, continue to Section 6.

b. **Identification of subcontractors and suppliers.** Prime contractor will list subcontractors and suppliers, if known, and their phone numbers.

Co:	Ph:
Co:	Ph:
Co:	Ph:
Co:	Ph:

c. **Means for controlling subcontractors and suppliers.** Prime contractor will meet with subcontractors and suppliers before work begins, and periodically thereafter, to coordinate activities and schedules, and to resolve any safety issues that may arise.

d. **Subcontractor and supplier safety responsibilities.** Subcontractors and suppliers will adhere to the requirements of the prime contractor's APP. Prime contractor will have subcontractors and suppliers sign the accident prevention plan signifying their understanding of, and compliance with, its provisions.

SUBCONTRACTOR AND SUPPLIER ACCEPTANCE OF ACCIDENT PREVENTION PLAN

Name:	Date:
Signature:	

Name:	Date:
Signature:	

Name:	Date:
Signature:	

Name:	Date:
Signature:	

Name:	Date:
Signature:	

6. TRAINING

a. **Safety indoctrination subjects.**

- Personal protective equipment requirements for project site.
- Review of accident prevention plan and activity hazard analyses.
- Weekly (employees) and monthly (supervisors) safety meetings.
- Location of portable fire extinguishers.
- Location of first-aid kits.
- Identification of first-aid/CPR qualified personnel (if applicable).
- Location of emergency phone numbers.
- Location of the nearest on-site/off-site medical facility.
- Emergency plans for fires/spills (if applicable).
- Accident notification and reporting procedures.
- Current project site safety issues.

Other safety indoctrination subjects.

b. Training or certifications applicable to the project. (Note: If the activity selected is in **bold** the prime contractor will provide employee names working the job along with their years of 'on-the-job' experience in **Appendix VI**. If workers have attended a specific training class or hold a certification in the job the prime will also annotate this information – **See Appendix VI.**)

- | | |
|---|--|
| <input type="checkbox"/> Abrasive blasting. | <input checked="" type="checkbox"/> Fall protection. |
| <input type="checkbox"/> Blasting. | <input checked="" type="checkbox"/> First-aid/CPR. |
| <input type="checkbox"/> Compressed gas cylinders. | <input checked="" type="checkbox"/> Formwork/shoring. |
| <input checked="" type="checkbox"/> Concrete/masonry. | <input checked="" type="checkbox"/> Hand/power tools. |
| <input type="checkbox"/> Confined space. | <input type="checkbox"/> Hazard communication. |
| <input type="checkbox"/> Cranes/derricks. | <input type="checkbox"/> Hazardous waste. |
| <input type="checkbox"/> Crane hand signals. | <input type="checkbox"/> Lockout/tagout. |
| <input checked="" type="checkbox"/> Electrical. | <input checked="" type="checkbox"/> Machinery/mechanized equipment. |
| <input type="checkbox"/> Elevating work platforms. | <input type="checkbox"/> Motor/all-terrain vehicles. |
| <input type="checkbox"/> Emergency response (fires/spills). | <input type="checkbox"/> Pneumatic tools. |
| <input checked="" type="checkbox"/> Excavation. | <input checked="" type="checkbox"/> Portable fire extinguishers. |
| <input type="checkbox"/> Explosive-actuated tools. | <input type="checkbox"/> Powered industrial trucks. |
| <input type="checkbox"/> Pressurized equipment/systems. | <input checked="" type="checkbox"/> Scaffold systems. |

- Respiratory protection.
- Rigging.
- Rotating work platform.
- Safe lifting techniques.
- Steel erection.
- Vehicle-mounted elevating platforms.
- Wearing/maintaining PPE.
- Welding/cutting.**

Other training and certifications.

--

c. Weekly employee safety meetings.

- Project manager, safety manager, site safety and health officer, or supervisor will conduct employee safety meetings.
- Prime contractor and subcontractor workers will attend employee safety meetings.

Day and time of employee safety meetings is listed below:



Day:	Time:
Day:	Time:

- Meetings will be documented with facilitator/attendee names, date, and subjects discussed.

d. Monthly supervisory safety meetings.

- Company owner, safety manager; or project manager will conduct supervisory safety meetings.
- Prime contractor and subcontractor supervisors will attend supervisory safety meetings.

Day and time of supervisory safety meeting is listed below:



Day:	Time:
Day:	Time:

- Meetings will be documented with facilitator/attendee names, date, and subjects discussed.

7. SAFETY AND HEALTH INSPECTION

a. **Project site safety inspections.**

- Company safety manager (periodically).
- Project manager (periodically).
- Supervisors and foremen (periodically).
- Site safety and health officer (SSHO) (frequently).
- Quality control representative (daily).
- Employees will conduct project site inspections of electrical cords, in-use hand and power tools, and in-use machinery/mechanized equipment (daily).

b. **Inspector qualifications.** Prime contractor will provide inspector qualifications for safety manager, SSHO, and quality control representative.

c. **Deficiency log.** A deficiency log will be generated after inspections using the criteria listed below. Follow-up inspections will be performed to ensure identified deficiencies have been corrected.

- Date deficiency identified.
- Description of deficiency.
- Name of person responsible for correcting deficiency.
- Projected resolution date.
- Date actually resolved.

d. **External inspections.** Are external inspections or certifications required? Yes No

If yes please explain.

8. ACCIDENT REPORTING

a. **Exposure data.** Man-hours worked will be reported to NAVFAC EURAFSWA Project Manager by the 25th of every month using the “Contractor Monthly Safety Self- Evaluation Form”(must insert in **Appendix VIII**).

b. **Accident notification.** Prime contractor will report accidents and incidents as soon as they happen to the contracting officer’s representative (COR). The COR, in turn, will notify the Safety Office according to the notification information below. For accidents and incidents that require immediate notification, the prime contractor will seal-off the site and wait for the NAVFAC Safety investigation team.

Immediate notification (telephonically):

- Fatality.
- Permanent total disability.
- Permanent partial disability.
- Three or more persons admitted to a hospital.
- Property damage of \$200,000 damage or more.

24-hour notification (telephonically and/or email):

- Lost time (**Note:** Lost time is defined as any loss of time away from work beyond the day or shift on which it occurred).
- Property damage not less than \$2,000 but no greater than \$200,000.
- Treatment of medical injuries not resulting in lost time.

c. **Accident recording.** Prime contractor will coordinate with the COR on forwarding the appropriate documents to the NAVFAC Safety Office.

Reportable accident and incident requirements: All accidents and incidents to include occupational injuries and illnesses that result in medical treatment with no lost time, and property damage of less than \$2,000, will be documented in an email and sent to the NAVFAC Safety Office within 24 hours.

Recordable accident and incident requirements: All accidents and incidents to include occupational injuries and illnesses that result in lost time (measured in days) or property damage of \$2,000 or more will be documented on ENG Form 3394 ‘U.S. Army Corps of Engineers Accident Investigation Report’ dated March 1999 and submitted to the NAVFAC Safety Office within five (5) days of the occurrence.

9. PLANS (PROGRAMS, PROCEDURES)

A. LAYOUT PLANS – MUST INSERT IN APPENDIX IX.

B. EMERGENCY RESPONSE PLANS – SEE APPENDIX IX.

C. MEDICAL SUPPORT.

a. General requirements.

An effective means of communication (hard-wired, cellular, or two-way radio and tested in the area of use for functionality) with emergency response source access will be provided along with transportation for injured workers.

Telephone numbers of medical facilities, physicians, and ambulances will be conspicuously posted (at a minimum these numbers will be posted near project-office telephones).

A map showing the best route to the nearest medical facility will be conspicuously posted.

Medical Facility Name:

Address:

Phone Number(s):

b. Type of medical support:

Less than 100 persons employed on any one shift. On sites with less than 100 workers, and where neither a first-aid station nor infirmary is available, prime contractor will provided a first-aid kit for every 25 persons. These kits will have latex gloves and a CPR shield.

Location of first-aid kits:

Trained first-aid/CPR employees. Prime contractor will have at least two employees on each shift trained to administer first-aid/CPR when a medical facility or physician is not accessible within five minutes of an injury to a group of two or more employees. Provide training certificates or copy of certification card.

Employee Name:

Certification expiration date:

Employee Name:

Certification expiration date:

More than 99 but less than 300 persons employed on any one shift. On sites with more than 99 but less than 300 workers the prime contractor will establish and equip, as directed by a licensed physician, a first-aid station. Identification signs and directional markers will be used to denote the station's location. Emergency lighting will be provided and a first-aid attendant will be on duty at all hours when work is in progress.

300 or more persons employed on any one shift. On sites with 300 or more workers the prime contractor will establish and equip, as directed by a licensed physician, an infirmary. Identification signs and directional markers will be used to denote the infirmary's location and emergency lighting will be provided.

Infirmaries will provide reasonably quiet conditions with some privacy, lighting, climate control, adequate toilet facilities, hot and cold water, drainage, and electrical outlets. Walls and ceilings will be finished with two coats of white paint, windows and doors screened, and the floors made of impervious construction.

A properly-equipped emergency vehicle, helicopter, or mobile first-aid unit will be provided during work hours (the emergency vehicle will not be used for any other purpose). A registered nurse, licensed physician's assistant, certified emergency medical technician, or a licensed practical nurse (approval by a licensed physician) will be assigned on a full-time basis to each work site.

D. PERSONAL PROTECTIVE EQUIPMENT (PPE).

a. General Requirements.

- Prime contractor will conduct hazard assessments to find out the type(s) of PPE required.
- Prime contractor will ensure workers know how to put on, adjust, wear, remove, and use PPE. PPE will be inspected before each use, maintained in a serviceable and sanitary condition, and stored so the integrity of the equipment is protected. This training will be documented with the name of the facilitator/attendees, date, and subjects taught.
- Damaged and defective equipment will not be used but rather marked 'out-of-service' and removed from the project site.

b. PPE used on the project site.

- | | |
|--|--|
| <input checked="" type="checkbox"/> Minimum required clothing. | <input type="checkbox"/> Welding goggles. |
| <input checked="" type="checkbox"/> Hard hat. | <input type="checkbox"/> Welding hand-held shields. |
| <input checked="" type="checkbox"/> Safety glasses/goggles. | <input type="checkbox"/> Full-body harness w/lanyard(s). |
| <input type="checkbox"/> Face shield. | <input checked="" type="checkbox"/> Reflective vest. |
| <input checked="" type="checkbox"/> Ear plugs/muffs. | <input checked="" type="checkbox"/> Dust mask. |
| <input checked="" type="checkbox"/> Work gloves. | <input type="checkbox"/> Half-face/full-face respirator. |
| <input type="checkbox"/> Welding gloves. | <input type="checkbox"/> Personal floatation device. |
| <input checked="" type="checkbox"/> Steel-toed/hard-soled shoes. | <input type="checkbox"/> Life ring. |
| <input type="checkbox"/> Welding helmet. | <input type="checkbox"/> |

Other PPE used on the project site.

E. OTHER PLANS: Must check if “YES” or NA (not applicable) for all listed plans. If you check “YES” then you must complete Appendix IX boxes for that plan or insert your company plan. Sections in parenthesis refer to plan coverage in the 2008 EM 385-1-1.

PLAN NAME	YES	NA	PLAN NAME	YES	NA
Plan for prevention of alcohol and drug abuse (01.C.02)	×		Contingency plan for severe weather (19.A.03);	×	
Site sanitation plan (Section 02)	×		Float Plan (19.F.04);		×
Access and haul road plan (4.B)		×	Site-Specific Fall Protection & Prevention Plan (21.C);	×	
Respiratory protection plan (05.G)		×	Demolition plan (to include engineering survey) (23.A.01);	×	
Health hazard control program (06.A)		×	Excavation/trenching plan (25.A.01);	×	
Hazard communication program (06.B.01)		×	Emergency rescue (tunneling) (26.A.);		×
Lead abatement plan (06.B.05 & specifications);		×	Underground construction fire prevention and protection plan (26.D.01);		×
Asbestos abatement plan (06.B.05 & specifications);		×	Compressed air plan (26.I.01);		×
Safety Program (06.E.03.a);	×		Formwork and shoring erection and removal plans (27.C);	×	
Abrasive blasting (06.H.01);		×	Precast Concrete Plan (27.D);		×
Heat/Cold Stress Monitoring Plan (06.I.02)		×	Lift slab plans (27.E);		×
Crystalline Silica Monitoring Plan (Assessment) (06.M) ;		×	Steel erection plan (27.F.01);		×
Night operations lighting plan (07.A.08);		×	Site Safety and Health Plan for HTRW work (28.B);		×
Fire Prevention Plan (09.A);	×		Blasting Safety Plan (29.A.01);		×
Wild Land Fire Management Plan (09.K);		×	Diving plan (30.A.13);		×
Hazardous energy control plan (12.A.01);		×	Confined space Program (34.A).		×
Critical lift Plan (16.H);		×			

10. RISK MANAGEMENT PROCESSES (AHA – ACTIVITY HAZARD ANALYSIS)

Instructions

1. List each definable feature of work / phase of work in the table below. NOTE: Definable feature of work / phase of work should be same as listed in Section 2.d. of this APP)
2. For each listed phase/feature complete an Activity Hazard Analysis form (See Figure 1-2 page 10 of EM 385-1-1) and insert into Appendix X.

ID No.	Feature of work / phase of work
1	Mobilization / General Construction
2	Demolition
3	Scaffolding / Fall Protection
4	Excavation / Trenching
5	Electrical
6	
7	
8	
9	
10	

APPENDIX I.

SIGNATURE SHEET

**(Reserved if more space is needed other than
Section 1)**

APPENDIX II.

BACKGROUND INFORMATION

Required Enclosures:

Optional:

Copy of project description from SOW, etc.

APPENDIX III.

STATEMENT OF SAFETY AND HEALTH POLICY

Required Enclosures:

- 1. Copy of signed company statement of Safety and Health Policy (if not using generic option in Section 3).**
- 2. The Contractor's written safety program goals, objectives, and accident experience goals for this contract (if not using generic option in Sections 2 and 3).**

Optional:

APPENDIX IV.

RESPONSIBILITIES AND LINES OF AUTHORITY

Required Enclosures:

- 1. Contractor's Resume and "USACE 30 hour Construction Safety Course certificate for SSHO" or equivalent certificate issued and acknowledged by local authorities.**
- 2. Proof of competency / qualification (Resumes and certificates) for the other persons listed in Section 4.**
- 3. Organization Chart (with names) for Key Corporate and Project personnel.**
- 4. Corporate/Company accountability policies and procedures (if not using generic option).**

Optional:

APPENDIX V.

SUBCONTRACTORS AND SUPPLIERS

Required Enclosures:

Optional:

Copies of Subcontractor Safety policies and procedures

APPENDIX VI.

TRAINING

Required Enclosures:

Company Safety and Occupational Health (SOH) Training policies, procedures, and plans (if not using generic option in Section 6).

Optional:

Company SOH training documents – such as training logs, certificates, etc.

SPECIFIC WORKER TRAINING

Abrasive blasting.

Name:	Training:
Name:	Training:
Name:	Training:

Blasting.

Name:	Training:
Name:	Training:
Name:	Training:

Confined space.

Name:	Training:
Name:	Training:
Name:	Training:

Cranes/derricks.

Name:	Training:
Name:	Training:
Name:	Training:



Electrical.

Name:	Training:
Name:	Training:
Name:	Training:

Explosive-actuated tools.

Name:	Training:
Name:	Training:
Name:	Training:

First-aid/CPR.

Name:	Training:
Name:	Training:
Name:	Training:

Lockout/tagout.

Name:	Training:
Name:	Training:
Name:	Training:



Machinery/mechanized equipment.

Name:	Training:
Name:	Training:
Name:	Training:

Scaffolding.

Name:	Training:
Name:	Training:
Name:	Training:

Welding/cutting.

Name:	Training:
Name:	Training:
Name:	Training:

APPENDIX VII.

SAFETY AND HEALTH INSPECTION

Required Enclosures:

- 1. Company safety and health inspection policies, procedures, and forms. (if not using generic option Section 7).**
- 2. Documents supporting Section 7 requirements.**

Optional:

APPENDIX VIII.

ACCIDENT REPORTING

Required Enclosures:

- 1. Company accident reporting policies, procedures, and forms. (if not using generic option in Section 8).**
- 2. Documents supporting Section 8 requirements.**

Optional:

APPENDIX IX.

PLANS

Required Enclosures:

- 1. Area map showing site location.**
- 2. Site layout map also showing site lay down areas, sanitation facilities, on-site medical support location (e.g. 1st Aid Kit), emergency telephone location and numbers.**
- 3. Acknowledgement of key provisions of all required plans – or copies of company SOH policies, procedures, or plans related to requirements.**

Optional:

Temporary facilities/layout plan (Section 4.A).
*****Written Company plan required**

NA.

- Trailers and other temporary structures used as field offices, personnel housing, or storage areas will be anchored with rods and cables or by steel straps attached to ground anchors.
- Temporary facility spacing requirements will be in accordance with (IAW) paragraph 09.A.19.
- Temporary power distribution requirements will be IAW paragraph 11.D.01.
- Temporary project fencing will be provided on projects located in areas used by the public.
- Signs warning of construction hazards will be posted on fencing every 300'.
- Temporary structures with an electrical capability will be grounded.
- Temporary work camps will be adequately drained (graded and ditched) and rendered free from depressions where water may settle.
- The area surrounding the structures will be free of debris, garbage, and rubbish.
- Temporary sleeping quarters will be heated, ventilated, lighted, and maintained in a clean and safe condition.

Emergency response plans for fires/spills (Section 01.E.01).
*****Written Company plan required.**

NA.

- Discuss escape procedures and routes.
- Designate critical project site operations and discuss how the operations will be protected.
- Discuss employee accountability procedures following an evacuation.
- Discuss employee roles in emergencies to include responsibilities and equipment used.
- Discuss the location of emergency contact information to include reporting procedures.

Hazard communication plan (Section 06.B.01).
*****Written Company plan required.**

NA.

- A current inventory of project site hazardous chemicals will be prepared.
- Material safety data sheets for hazardous substances will be kept at the project site.
- Containers will be labeled with the type of hazardous substance they contain.
- Workers will be notified about new substances that are brought onto the worksite to include the hazards associated with them.

Respiratory protection plan (Section 05.G.03).
*****Written Company plan required.**

NA.

- Discuss the use of dust masks to protect workers from large particulate matter.
- Discuss the use of half-faced respirators to protect workers from small particulate matter to include fumes, mists, and aerosols.
- Discuss sealing a half-face respirator properly.
- Discuss cleaning a half-faced respirator properly
- Discuss inspecting and storing a half-face respirator properly.

Health hazard and control plan (Section 06.A.02(b)). **NA.**
An activity hazard analysis (AHA) will be completed for each applicable area.

- Discuss hazardous substances.
- Discuss hot substances (heating devices and melting kettles).
- Discuss harmful plants, animals, and insects.
- Discuss ionizing radiation.
- Discuss the use of lasers.
- Discuss ventilation and exhaust systems.

Abrasive blasting plan (Section 06.H.01(b)). **NA.**
*****Written Company plan required.**

Confined space plan (Section 34.A.06). **NA.**
*****Written Company plan required.**

- Discuss responsibilities of attendants, entrants, and entry supervisors.
- Train workers how testing and monitoring equipment is used.
- Discuss the type of ventilating equipment needed to obtain acceptable entry conditions.
- Discuss the type of communication equipment to be used.
- Discuss the PPE to be used when engineering and/or administrative controls fail to protect workers adequately.
- Discuss the lighting equipment to be used.
- Discuss the equipment to be used for entrant ingress and egress.
- Discuss rescue procedures to include required equipment and emergency phone numbers.

Hazardous energy control plan (Section 12.A.12). **NA.**
*****Written Company plan required.**

- Discuss why the lock out/tag out procedure is being used.
- Communicate and coordinate the lockout/tagout procedure with the workers being affected by the procedure and the government's designated authority.
- Discuss the procedural steps in place for shutting down, isolating, blocking, and securing systems to control the release of hazardous energy to include the person(s) responsible for performing this task.
- Discuss the procedural steps in place for placing, removing, and transferring lockout/tagout devices to include the person(s) responsible for performing this task.
- Discuss the procedural steps in place for placing and removing locks and/or tags to include the person(s) responsible for performing this task.
- Discuss the procedures for testing the effectiveness of isolating hazardous energy to include lockout/tagout.
- Discuss emergency scenarios that could arise during the lockout/tagout procedure to include the actions to be taken for safely responding to an emergency.
- Discuss the procedure for transferring removal authority from one person to another.

Critical lift plan (Section 16.H.02).
***Written Company plan required.

NA.

- Designate a crane operator, lift supervisor, and rigger (and state their qualifications).
- Describe ground conditions and outrigger and crawler track requirements.
- Discuss crane position, height of the lift, load radius, and boom angle and length for the entire range of the lift.
- Discuss the size and weight of the load to include any crane and rigging components that add to the weight.
- Discuss the rigging plan to include lift points, hardware requirements, and procedures.
- Discuss coordination of the lift and how individual players will communicate with each other.
- Discuss tandem and tailing-crane lift procedures, if applicable.
- Describe environmental conditions which, when in effect, will stop the lift.

Access and haul roads plan (Section 04.B).
***Written Company plan required.

NA.

- Discuss equipment to be used on the road, traffic density, and the hours of operation.
- Discuss road layout and widths, horizontal and vertical curve data, and sight distances.
- Discuss sign and signalperson requirements, road markings, and traffic-control devices.
- Discuss how drainage will be controlled.
- Outline contact between vehicles and the public to include implementing safety controls at each one of these places.
- Discuss the maintenance needed to keep the roads hard, smooth, and as dust-free as possible.

Demolition plan (Section 23.A.01).
***Written Company plan required.

NA.

- A demolition plan based on engineering, lead, and asbestos surveys will be prepared.
- Utilities and other service lines will be shut-off, capped, or otherwise controlled outside the building line.
- Service lines will be temporarily relocated and protected if utilities are maintained.
- If hazardous building materials and chemicals, flammable materials, explosives, gases, or other dangerous substances have been used in building construction, pipes, tanks, or other equipment on the property they will be controlled or eliminated before demolition begins.
- Glass fragmentation will be controlled.
- Mechanical equipment will not be used on floors or other working surfaces unless the floors and surfaces are of sufficient strength to support the loads.
- Chute openings will be protected by a guardrail 42" in height. When debris is dropped through floor openings without chutes, the openings and the area onto which the material is dropped will be enclosed with barricades not less than 42" in height and not less than 6' back from the protected edge of the opening above. Signs warning of the fall-material hazard will be posted at each side of the debris opening at each floor.
- No wall section more than 6' in height will stand without lateral bracing unless the wall was designed and constructed to stand without this support and its condition is determined safe enough to be self-supporting.
- Workers will not be allowed in the area directly underneath floor arches when they're being removed. The area will be barricaded to prevent access and signed to warn of the hazard.

- Steel construction will be dismantled column-by-column and tier-by-tier (columns may be in two-story lengths).

Compressed air and gas systems plan (Section 20.B). **NA.**
No written plan required.

- Compressors and related equipment will be located so safe access is provided to all parts of the equipment for operation, maintenance, and repairs.
- Air hose, pipes, valves, filters, and other fittings will be pressure-rated by the manufacturer and not exceeded. Defective hose will be removed from service.
- Hose will not be laid over walkways, steps, ladders, and scaffolds to create a tripping hazard.
- Compressed air will not be used to blow dirt from the hands, face, or clothing.
- A speed governor independent of the unloaders will be installed on air compressors except those driven electrical induction or electrical synchronized motors.
- Piping will be equipped with traps or other means for removing liquid from the lines.
- Air receivers will be installed so that all drains, hand holes, and manholes are accessible.

Formwork/shoring (Section 27.C). **NA.**
*****Written Company plan required.**

- Formwork, shoring, and bracing will be erected and maintained to safety support all vertical and lateral loads that might be applied until such loads can be supported by the structure.
- Sills will be sound, rigid, and capable of carrying the maximum intended load.
- Base plates, shore heads, extension devices, or adjustment screws will be in firm contact with the sill and form material and, as applicable, will be snug against the posts.
- Diagonal bracing will be provided in vertical and horizontal planes to provide stiffness and to prevent buckling of the individual members.
- Forms and shores (except those on slab or grade and slip forms) will not be removed until the concrete has gained sufficient strength to support its weight and all superimposed loads.

Lift-Slab Operations (Jacking plan) (Section 27.E). **NA.**
*****Written Company plan required.**

- Manufacturer's rated capacity will be legibly marked on all jacks and not exceeded.
- Jacks will be designed and installed so they won't continue to lift when overloaded.
- Jacks will have a positive stop to prevent over-travel.
- Base of the jack will be blocked or cribbed. If there's a possibility of slippage a wood block will be placed between the jack's metal cap and the load.
- Maximum number of manually-controlled jacks on one slab will be limited to 14.
- During lifting all point of the slab support will be kept within 1/2" of that needed to maintain the slab in a level position.
- No one will be permitted under the slab during jacking operations.

Personal Fall Protection Program (Section 21.C.01). **NA.**
*****Written plan required.**

- Workers will be protected by guardrail, personal fall protection, safety nets, catch platforms, or temporary floors in the following situations: Worker can fall 6' or more; on access ways or work platforms over water, machinery, or dangerous operations; on runways where workers can fall 4' or more; and on all exposed sides of stairways and ladder-floor openings.
- Top rails, mid rails, and toe boards will be able to withstand outward and downward forces of 200, 150, and 50 lbs., respectively.
- Wire rope can be used as a top or mid rail under the following conditions: When the posts are spaced no farther than 8"; deflection of the rope under 200 lbs. of force is less than 3"; and the rope is flagged for visibility. Synthetic and natural-fiber rope will not be used.
- Paneling and screening will be in place from the mid rail to the toe board when material is piled higher than the toe board.
- Personal fall protection will consist of a full-body harness (not chest-wait units or body belts), lifeline, and anchorage point.
- Two lanyards will be used when vertical movement is required and when a horizontal lifeline is inappropriate.
- Anchorages capable of supporting 5,000 lbs. per worker will be independent of anchorages used to support or suspend platforms. Lifelines will not be attached to guardrails or hoists but rather to the structure.
- Floor holes will be covered completely and securely. If the cover to an open hole is missing the hole will be barricaded with a guardrail. Workers laboring by wall openings 6' or more above a lower level will be protected by a guardrail or personal fall protection.
- Roofers will be protected by the following forms of fall protection: Guardrails; personal fall protection; a warning line 6' from the roof's edge, or a safety-monitoring system.
- Excavations will be guarded when they are 6' or more in depth and not readily seen because of plant growth or other visual barriers.

Steel Erection Plan (Section 27.F). **NA.**
***Written Company plan required.

Night operations lighting plan (Section 7.A.08). **NA.**
***Written Company plan required.

Site sanitation plan (Section 02.A). **NA.**
No written plan required.

- An adequate supply of drinking water (cool water during hot weather) will be provided.
- Portable drinking-water dispensers will have a tap – water will not be dipped. Dispensers will be clearly marked as "Drinking Water" and will be capable of being closed. Use of a common cup will be prohibited unless sanitized between uses.
- When sanitary sewers are not available porta-johns will be provided.
- Washing facilities will have running water, soap, and an individual means of drying (hand sanitizer will be used when running water is not practical).
- No food or beverage will be stored or consumed in a toilet room or in any area that is exposed to a toxic material.
- An adequate number of waste receptacles will be provided. Receptacles will have covers that fit tightly, be emptied at least daily, and be maintained in a sanitary condition.

Fire Prevention Plan (Section 09.A). **NA.**
***Written Company plan required.

- Discuss the major worksite fire hazards to include potential ignition sources.
- Describe the types of fire-suppression systems to be used (portable fire extinguishers, etc.).
- Discuss employee responsibilities for maintaining the fire-prevention equipment and systems.
- Discuss employee responsibilities for controlling fuel-source hazards.
- Discuss housekeeping procedures to include the removal of waste materials.

Excavations (Section 25.A).

NA.

*****Written Company plan and AHA required for excavations or trenches greater than 5 ft (1.5 m) in depth. For excavations or trenches less than 5 ft (1.5 m) in depth, An AHA is required but plan is optional.**

- Workers will not labor in excavations in which there is accumulated water or where water is accumulating until the water hazard is controlled.
- Shoring will be used for unstable soil or depths greater than 5' unless benching, lay-back, or another acceptable plan can be implemented.
- In excavations less than 20' in depth the maximum slope will be 34 degrees measured from horizontal (1 1/2' horizontal to 1' vertical).
- Excavations will not go below adjacent structures unless they are underpinned or determined safe by a registered professional engineer.
- Excavated material will be placed a minimum of 2' from the excavation's edge.
- Stairs, ramps, or ladders will be provided to workers who are required to enter excavations greater than 4' in depth. This equipment will be located so no more than 25' of lateral travel is required to escape the excavation.
- Ladders will extend 3' past the excavation's edge.
- Personal access ramps will be 4' wide with guardrails while equipment ramps will be 12' wide with curbs of 8" X 8" timbers or equivalent.
- Protection for excavations exposed to the public will meet guardrail requirements while protection against vehicles will be able to withstand the impact forces with traffic.
- Excavations 6' or more in depth, or where workers are routinely exposed to a hazard (impalement or hazardous material), will have a barricade no closer to the edge than 6' with a warning (tape, flags, act.) located 3-4' above the ground.
- Excavations less than 6' in depth will have a barricade no closer than 6"/no farther than 6'.

**Scaffolds (Section 21.J.01, 21.J.02 on page 509 and 22.A and 22.B).
No written plan required (included as part of the Fall Protection Plan).**

NA.

- Scaffolds will be level and plumb and erected with base plates upon mudsills or other adequate foundation. Rolling scaffolds will have wheels locked and/or outriggers secured in place.
- Work near overhead power lines will not commence until a survey is made to ascertain a safe clearance distance from the lines. Scaffolds will not be erected or used near power lines until the lines are insulated, de-energized, or rendered safe.
- Scaffolds and their components will be capable of supporting four times the maximum anticipated load. If a scaffold's height is more than four times the minimum base dimension (to include the width added by outriggers) it will be secured to the wall or structure.
- Guardrails will be installed on open sides and ends.
- Platforms will be a minimum of 18" in width and extend over their end supports by at least 6" but no more than 12", unless cleated or restrained by hooks or equivalent means. Platforms will overlap over supports by a minimum of 12" unless nailed together or restrained from movement.

- Platform area will be fully-planked with no greater than 1" gaps between adjacent platforms, and platforms and uprights.
- Scaffold access will be from ladders (bottom rung no greater than 24" in height), stair towers, ramps, and walkways but not from cross-braces.
- If a worker can fall 6' or more to a lower level they will be protected by a guardrail or a full-body harness with lifeline and anchorage point.

Machinery/mechanized equipment (Section 18.G).
No written plan required.

NA.

- Before machinery and mechanized equipment is placed into service it will be inspected and certified as safe by a competent person.
- Front-end loaders, bulldozers, backhoes, cranes, and similar equipment will have at least one dry chemical or CO2 portable fire extinguisher on-board with a minimum rating of 5-B:C.
- Self-propelled construction equipment will have a reverse signal alarm.
- Belts, gears, chains, shafts, pulleys, drums, and other rotating and moving equipment parts will be guarded when exposed to contact by persons or when they otherwise create a hazard.
- Crane will operate at least 10' away from overhead power lines.
- An operating manual, log book, load chart, and document detailing operating limits in windy or cold weather conditions will be in the cab when the crane is operating.
- Crane will be within one degree of level and outriggers fully-extended when in use. Wheels will be off the ground at every setting.
- Crane outrigger floats will be securely attached. Float blocking will be of sufficient size and stability to support the total area. Blocking will not be performed under the outrigger beams.
- Crane's rear swing radius will be barricaded.
- Riding on or standing under loads is prohibited.

Electrical (Section 11).
No written plan required.

NA.

- Electrical work shall be performed by Qualified Personnel with verifiable credentials.
- An AHA and written work procedures must be prepared for unusual or complicated work activities or any activity identified by the Qualified Person.
- Work activity adjacent to energized overhead power lines will not be initiated until a survey has been made to ascertain the safe clearance distance from the lines.
- Whenever possible, all circuits and equipment will be de-energized before work is started and personnel protected by lockout/tagout and clearance procedures, and grounding.
- Live parts of wiring or equipment will be guarded.
- Transformer banks and high-voltage equipment will be protected against unauthorized access and those entrances not under constant observation will be kept locked. Metallic enclosures will be grounded and signs warning of high voltage and prohibiting unauthorized entrance posted.
- Flexible cords will be inspected by the user daily. Cord sets used on construction sites or in damp locations will contain an equipment ground wire and have a plug attached.
- Flexible cords will be protected from damage caused by vehicles, foot traffic, sharp corners, and pinching. Cords passing through holes will be protected by suitable means.
- Flexible cords will only be used in continuous lengths. Cords No. 12 or larger may be used with a splice if the splice is made by a qualified electrician, the insulation is equal to the cord being spliced, and the wire connections are soldered. No wire nuts will be used.
- Flexible cords and cables will not be secured by staples or hung from nails or bare wire.

- Enclosures containing over-current protective devices will be provided with lockable, close-fitting doors. Circuit-breakers, switches, fuse panels, and motor controllers located out-of-doors or in wet locations will be contained in weatherproof enclosures or cabinets. When receptacles are used in wet locations they will be contained in a weatherproof enclosure the integrity of which is not affected when a plug is inserted.
- All electrical circuits will be grounded.
- Portable and semi-portable electrical tools and equipment will be grounded by a multi-conductor cord having a polarized plug with a grounding conductor. Double-insulated tools do not have to be grounded.
- Grounding rods with pipe electrodes will be used in 8' lengths and driven to full depth.
- Temporary lights will not be suspended by their electric wire unless designed for suspension.
- Bulbs attached to temporary lighting strings and extension cords will be protected by guards. Empty light sockets (broken bulbs, etc.) will be immediately filled.
- All receptacle outlets that provide temporary electrical power during construction or demolition shall have GFCI protection.

APPENDIX X.

RISK MANAGEMENT PROCESSES (AHA – ACTIVITY HAZARD ANALYSIS)

Required Enclosures:

- 1. One completed AHA form for each phase of work / feature of work. Refer to AHA template and include the completed forms in Appendix X.**

Activity Hazard Analysis Template

How to use this document

**This first page is NOT to be included in the APP you're going to submit.
PLEASE DELETE IT BEFORE PRINTING THE FILLED DOCUMENT**

Directions:

Activity Hazard Analysis [AHA] is required for each definable feature of work (DFOW).

However, many if not all projects involve one or more of the following activities as part of one or more DFOWs.

Work Activities:

- a. Mobilization / General Construction*
- b. Demolition*
- c. Scaffolding / Fall Protection*
- d. Excavation / Trenching*
- e. Electrical*

*Contractors are authorized to include the attached **Generic AHAs** relevant to each of the above said activities in their submittal and then incorporate them by reference in their DFOW AHAs rather than repeat this information.*

NOTE: *To use the Generic AHA you MUST complete the table at the following page (to be part of your submittal) and fill **all** blanks and areas denoted by the **RED** arrow in each generic AHA including checking the "Accepted as part of the APP" box at the bottom of the Generic AHA and completing the APP preparer signature box at the bottom right of each form. If any step or hazard reported in the AHA does not apply to your case it shall be deleted.*

The AHAs corresponding to the activities checked as "No" or "N/A" must be removed from the submittal package;

You can fill the general data automatically, just highlighting the rows Contract No, Project Name, Location, Contractor, Date on the following page, right-clicking the mouse and clicking the command "update". It is sufficient to click print preview once inserted the requested data to populate the rest of the document.

The AHA shall be submitted in pdf format and incorporated as Appendix X of the ACCIDENT PREVENTION PLAN [APP].

The Generic AHAs are not a substitute for full compliance with EM 385-1-1 requirement but are intended only to highlight selection items.

Activity Hazard Analysis

Contract No.: N33191-XX-X-XXXX

Project Name:

Location:

Date: MM/dd/yy

 Contractor's competent / qualified person:

The following Generic AHAs are incorporated into the site specific AHAs.

Generic AHA used in this APP	Yes	No/NA
G1 - Mobilization / General Construction	x	
G2 - Demolition	x	
G3 - Scaffolding / Fall Protection	x	
G4 - Excavation / Trenching	x	
G5 - Electrical	x	



ACTIVITY HAZARD ANALYSIS		
ID No. G-1	FEATURE OF WORK: GENERIC AHA – Mobilization / General Construction Hazards	
Contract No. N33191-XX-X-XXXX	Project: Xxxx	Location: Xxxx, XXXX
Date: MM/dd/yy	Activity:	Estimated Start Date:
PRINCIPAL STEPS	POTENTIAL SAFETY / HEALTH HAZARDS	RECOMMENDED CONTROLS
General Safety Requirements during mobilization and in general construction projects.	<ol style="list-style-type: none"> 1. Exposure to Cold or Hot Weather 2. Dehydration 3. Illnesses from improper sanitation 4. Injury from use of hand and power tools 5. Slip, Trip, Fall hazards 6. Back, shoulder, and other ergonomic injuries 7. Struck by / Caught between hazards from heavy equipment operations. 8. Injury from mines and unexploded ordnance. 	<p>1a. Minimum Personal Protective Equipment Dress:</p> <ul style="list-style-type: none"> • Long Pants • Shirts with Sleeves • Hardhat • Covered Shoes (Steel Toe Preferred) • Safety Glasses (Potential Eye Hazard Areas) • Reflective Safety Vest if working around heavy equipment or on/near roadways. <p>1b. Weather:</p> <ul style="list-style-type: none"> • Wear appropriate clothing for hot or cold weather. • Sun block • Lip balm <p>2. Dehydration:</p> <ul style="list-style-type: none"> • Drink at least ½ liter of water an hour. • Refer to Company quick sheet, SOPs, plan, etc. for specific details on heat stress signs and symptoms. <p>3. Provide approved potable water, toilet and hand washing facilities; food service, and waste disposal per EM 385-1-1 Section 2.</p> <p>4a. Use hand and power tools only if in good working condition and only for intended use. Inspect prior to each use.</p> <p>4b. Do not use any power tool that does not have the proper electrical grounding plug unless it is double insulated.</p> <p>4c. Provide proper guarding on all power tools – especially abrasive and grinding wheels.</p> <p>4d. Do not carry electrical power tools by the cord.</p> <p>4e. Provide all personal protective equipment necessary to control eye, face, head, body, and foot protection for the task.</p> <p>4f. Comply with other specific requirements of EM 385-1-1 Section 13.</p> <p>5a. Maintain housekeeping – maintain the work area free from debris such as board, blocks, rocks, etc. that might create a tripping hazard. (EM 385-1-1 Sec 14.C.)</p> <p>5b. Store all materials in a neat orderly manner. Do not stack beyond stable levels. (EM 385-1-1 Sec 14)</p> <p>5b. Provide adequate lighting for the work area – especially at night or during the day in areas without adequate natural light. (EM 385-1-1 Sec 7.A.)</p> <p>6a. Use proper lifting techniques for manual material handling.</p> <p>6b. Limit one man lifts to no more than 25 kg.</p> <p>7a. All vehicles and heavy equipment must be operated by qualified personnel and in accordance with manufacturer’s instructions.</p> <p>7b. Inspect all heavy equipment prior to use (EM 385-1-1 Sec 18.A.03)</p> <p>7c. Passengers must be seated and wearing seat belts during movement.</p> <p>7d. Backup alarms or ground guides must be used whenever backing where worker are present In the area.</p> <p>7e. Other provisions of EM 385-1-1 Section 18 must be followed.</p>

		<p>8a. Verify UXO clearance certificate in on file and to anticipated depth of construction for entire site area including lay-down yard.</p> <p>8b. Train all workers on 3Rs – Recognize, Retreat, Report for anticipated UXO. Use the clearance report to anticipate likely items to be found.</p> <p>8c. Train all workers in standard marking color code: White – safe, Blue – unexploded ordnance, Red – mines.</p> <p>All hazards – Post accident prevention signs, tags, labels, and signals at key points around project site in proximity to the hazard and at project entry of general site hazards. Conduct entry brief for all visitors to the site and provide all required PPE for safe entry.</p>
EQUIPMENT	INSPECTION REQUIREMENTS	TRAINING REQUIREMENTS
Hand and power tools Heavy Equipment	Hand and power tools inspected prior to use and per manufacturer's specifications. Heavy equipment when brought on site and per EM 385-1-1 Sec 18.	Proper use of hand and power tools Heavy equipment operator training for specific type, make, model of equipment. Specialized training for equipment as required by manufacturer. UXO hazard recognition, retreat, and report for probable site munitions.
<p>Prepared by: <Xxx Xxxx, xxxx> (Contractor's competent/qualified person signature)</p>		
<p><input checked="" type="checkbox"/> - AHA Accepted as part of project Accident Prevention Plan</p>		<p>Signature: <Xxxx></p> <p>Date: MM/dd/yy</p>



ACTIVITY HAZARD ANALYSIS		
ID No.	G-2	FEATURE OF WORK: GENERIC AHA – Demolition
Contract No. N33191-XX-X-XXXX	Project: Xxxx	Location: Xxxx, XXXX
Date: MM/dd/yy	Activity:	Estimated Start Date:
PRINCIPAL STEPS	POTENTIAL SAFETY / HEALTH HAZARDS	RECOMMENDED CONTROLS
1. Planning	1. Lead or asbestos exposure 2. Unplanned structural failure 3. Unplanned hazards from existing utilities	1. Conduct a lead and asbestos survey of the facility to be demolished prior to the start of work. 2. Evaluate the structural integrity of the building and prepare a demolition plan (See EM 385-1-1 Sec 23.A.01). 3. Identify all electric, gas, water, steam, sewer, and other service lines.
2. Demolition	1. General construction hazards. 2. Lead or asbestos exposure . 3. Unplanned structural failure. 4. Hazards from existing utilities. 5. Hazards from debris removal.	1. Follow mobilization and general construction generic AHA requirements. 2. Conduct lead and asbestos abatement per approved plan. 3a. Follow approved demolition plan for sequencing demolition. 3b. Unless specified otherwise in the demolition plan demolition of floors and exterior walls begin at the top of the structure and proceed downward. 3c. Control hazards from fragmentation of glass. 3d. Do not use mechanical equipment on floors that have not been structurally evaluated to support the imposed load. 3e. Competent person will make continuing inspections to detect hazards from weakened or deteriorating floors, wall, or loosened material. If detected do not work in area until hazard abated by shoring, bracing, or other means. 4. Shutoff, cap, or otherwise control outside the building line all utilities identified in Step 1 – planning. 5a. Manage debris removal IAW EM 385-1-1 Sec 23.B with regards to chutes, 5b. Never allow a vertical wall section more than 6 ft in height to stand without lateral bracing. 5c. Control dust exposure by wetting or other means. If this is not practical then provide respiratory protection to workers. 5d. Mark and manage area around demolition site to control falling debris hazard. 5e. Comply with other provisions of EM 385-1-1 Section 23 relevant to site specific demolition hazards.
EQUIPMENT	INSPECTION REQUIREMENTS	TRAINING REQUIREMENTS
Hand and Power tools. Sledge hammers, wrecking bars, and other demolition specific tools. Mechanical demolition equipment.	Inspect hand and power tools daily and per manufacturer's directions. Daily inspection of mechanical equipment per Sec 18 of EM 385-1-1.	Competent person training for demolition. Qualified operator training for all mechanical equipment.
Prepared by: <Xxx Xxxx, xxxx> (Contractor's competent/qualified person signature)		
<input checked="" type="checkbox"/> - AHA Accepted as part of project Accident Prevention Plan		Signature: <Xxxx>  Date: MM/dd/yy





ACTIVITY HAZARD ANALYSIS		
ID No. G-3	FEATURE OF WORK: GENERIC AHA – Scaffolding / Fall Protection	
Contract No. N33191-XX-X-XXXX	Project: Xxxx	Location: Xxxx, XXXX
Date: MM/dd/yy	Activity:	Estimated Start Date:
PRINCIPAL STEPS	POTENTIAL SAFETY / HEALTH HAZARDS	RECOMMENDED CONTROLS
1. Set-Up	1. Back Strain from unloading or moving scaffold components. 2. Lacerations on hands 3. Scaffold failure due to damaged scaffolding components. 4. Struck by mechanized equipment. 5. Loss of load. 6. Stuck by suspended loads or material. 7. Electrical Shock 8. Scaffold failure due to improper set-up	<p>NOTE: All items hazards and controls in generic AHA G1: Mobilization and General Construction Safety apply to this activity.</p> 1a. Utilize proper lifting techniques. 1b. Size up load before lifting. 1c. Ask for help when lifting heavy items more than 50 lbs. 2. Wear leather gloves. 3a. INSPECT all scaffolding components defects or damage such as cracks, excessive rust, metal fatigue, unauthorized repairs, bent tubing or frame, etc. <ul style="list-style-type: none"> • Frames • Tubing • Base Plates • Locking Pins • Access Ladder • Planking (Wood or Metal) • Cross Braces 3b. REMOVE damaged or defective scaffold components immediately. 3c. Attach tag or label “ DO NOT USE ” on scaffold component. 4a. ALWAYS maintain eye contact with operator of equipment. 4b. NEVER stand behind (Blind Spots) equipment. 4c. NEVER stand near unloading or moving of scaffold components. 4d. ONLY qualified operators shall operate equipment. 5a. Secure loads from displacement with ropes, cables, chains, etc. before movement. 5b. Ensure load to be lifted is secured, balanced, etc. 5c. Keep hands, fingers, or other body parts away from pinch points. 6a. NEVER stand underneath suspended loads. 6b. Use taglines to control loads when elevated. 7a. Check above for overhead power lines. 7b. NEVER erect scaffolding within 10 ft (3 m) of overhead power lines. Refer to EM 385-1-1, Table 11-1 for Minimum Clearance from Energized Overhead Electrical Lines 7c. NEVER string or hang temporary power cords, wires, etc. on metal scaffolding. Consult with Safety Officer. 8a. Inspect ground conditions (level and firm). 8b. Stable base is necessary for proper scaffold assembly. 8c. Scaffold shall be tied into structure when the scaffold height exceeds four times the minimum scaffold base dimension per EM 385-1-1, para 22.B.09 <i>Develop specific controls to eliminate or reduce each hazard to an acceptable level of risk.</i>
2. Assembly of Scaffolding	1 Fall from Elevated Heights 2. Scaffold Failure	1a. 100 percent fall protection required during assembly. 1b. Personnel shall not be exposed to unprotected sides or falls greater



	<p>3. Back Strain 4. Lacerations on hands</p>	<p>than 6 ft (1.8 m). 1c. Scaffolding shall not exceed 14 inches (35.5 cm) from the planking to the face of the building or structure. 1d. Scaffolding more than 14 inches (35.5 cm) from the planking to the face of the building or structure shall be guardrails and/or the use of personal fall protection. 1e. Personnel shall be tied off to a vertical lifeline with a rope grab during assembly of scaffolding. 1f. Vertical lifeline shall be secured to an anchor point of at least 5,000 lbs (2,267.9 kg) per individual. 1g. Contact Safety Officer for additional guidance on fall protection requirements. 2a. See diagram below and refer EM 385-1-1, Section 22 for specific requirements (i.e., toe boards, guard rails, safe access, etc.) 2b. Scaffolding shall be assembled on mud sills and base plates. 2c. Mud sills shall be at least 2 times the size of the base plates to disperse total weight of scaffolding. 2d. Scaffolding shall be plumb and level. 2e. Working levels shall be fully decked and/or planked. 2f. Planking shall extend over the end supports not less than 6 in (30.4 cm), 2g. Planking shall be secured, supported, or braced to prevent excessive spring or deflection and secured to prevent loosening, tipping, or displacement. Use of tie wire, cleats, etc. are options. 2h. Planking shall overlapped at least 12 inches (30.4 cm) or secured from movement. 2i. Scaffold shall be capable of supporting without failure at least 4 times the maximum anticipated loads. 2j. Scaffolding shall be all required cross, horizontal, or diagonal braces to secure vertical members laterally. 2k. Scaffolding shall be rigid. 3a. Utilize proper lifting techniques. 3b. Size up load before lifting. 3c. Ask for help when lifting heavy items more than 50 lbs. 4. Wear leather gloves.</p>
<p>3. Use of Scaffolding</p>	<p>Scaffold Failure Falls from Heights Slips, Trips, or Fall</p>	<p>1a. DO NOT overload more than 4 times the maximum load rating. 1b. DO NOT attached hoists or other material lifting devices without Safety Officer approval. 1c. Scaffolding shall be tied into building whenever height of the scaffold exceeds 4 times the minimal base. Refer to EM 385-1-1, para 22.B.09 for additional guidance. 1d. Scaffold usage shall cease during high winds or severe inclement weather conditions. 2a. Guardrails shall be used as primary fall protection. Guard rails shall installed IAW EM 385-1-1, para 21.B.02. 2b. Securing of personal fall protection devices to scaffolding is prohibited. 2c. Personnel shall have fall protection whenever above 6 ft (1.8 m). 2d. Climbing of braces or cross bracing is prohibited. 2e. Safe access (ladder) shall be provided. 2f. Personnel shall not stand on mid rails. 2g. Ladders shall extend at least 3 ft (0.9 m) past the work area. 3. Walking surfaces on and around scaffolding shall be clear of debris.</p>
<p>4. Disassembling of Scaffolding</p>	<p>1 Fall from Elevated Heights 2. Back Strain 3. Lacerations on hands</p>	<p>1a. 100 percent fall protection required during disassembly. 1b. Personnel shall not be exposed to unprotected sides or falls greater than 6 ft (1.8 m). 1c. Personnel shall be tied off to a vertical lifeline with a rope grab during assembly of scaffolding.</p>

		<p>1d. Vertical lifeline shall be secured to an anchor point of at least 5,000 lbs (2,267.9 kg) per individual.</p> <p>1e. Contact Safety Officer for additional guidance on fall protection requirements.</p> <p>2a. Utilize proper lifting techniques.</p> <p>2b. Size up load before lifting.</p> <p>2c. Ask for help when lifting heavy items more than 50 lbs.</p> <p>3. Wear leather gloves.</p>
EQUIPMENT	INSPECTION	TRAINING REQUIREMENTS
<p>Scaffold components Hammers Mud sills Full body harness Lanyard Lifeline Fall protection anchor points Float</p>	<p>Inspect scaffold components prior to use Inspect scaffold daily (Use Checklist) Inspect level and plumb of scaffoldings during erection and daily when in use. Daily Housekeeping of work areas and scaffolding</p>	<p>Competent Person qualification Scaffold Assembly Fall Protection Inspection of Work Platforms</p>
<p>Prepared by: <Xxx Xxxx, xxxx> (Contractor's competent/qualified person signature)</p>		
<p><input checked="" type="checkbox"/> - AHA Accepted as part of project Accident Prevention Plan</p>		<p>Signature: <Xxxx> </p> <p>Date: MM/dd/yy</p>







ACTIVITY HAZARD ANALYSIS		
ID No.	G-4	FEATURE OF WORK: GENERIC AHA – Excavation / Trenching
Contract No. N33191-XX-X-XXXX	Project: Xxxx	Location: Xxxx, XXXX
Date: MM/dd/yy	Activity:	Estimated Start Date:
PRINCIPAL STEPS	POTENTIAL SAFETY / HEALTH HAZARDS	RECOMMENDED CONTROLS
1. Prepare excavation / trench work area.	1. Struck by traffic in area. 2. Struck by / caught between heavy equipment. 3. UXO hazard.	NOTE: All items hazards and controls in generic AHA G1: Mobilization and General Construction Safety apply to this activity. 1a. Develop a traffic control plan for the work areas to keep traffic back from the planned excavation edge and work area. 1b. Wear proper reflective vest type for traffic. 1c. Use proper class perimeter protection (EM 385-1-1 pgs Q55-56 / Sec 25.B.) 2a. Plan for equipment laydown and operating area in traffic control plan. 2b. Perform initial and routine equipment inspections. 2c. Use ground guides in close proximity areas – no exceptions. 3. Verify UXO clearance certificate against work area location.
2. Open excavation / trench.	1. Struck by/ caught between traffic and heavy equipment. 2. UXO hazard. 3. Contact with buried utility lines (electrical, gas, etc.) 4. Cave in / Collapse.	1. Same as step 1 and 2 above controls. 2. Same as 3 above – plus regularly inspect dig for signs of buried UXO. 3a. Pre-locate all buried utilities. 3b. Observe for marking / signs of buried utilities during dig – barriers, warning tape, etc. 4a. Prepare excavation plan for all excavations over 5 ft (1.5m) in depth. Optional for excavations less than 5 ft – AHA is acceptable. (EM 385-1-1 Sec 25.A.01) 4b. Identify a Competent person for the planning and work. 4c. Evaluate soil type at all planned excavation depths. 4d. Design a protective system (e.g. Bench, slope, or shore) for the excavation per the soil type and other site conditions. 4e. Remove all overburden from edge of trench at least 2 ft. 4f. Protect the stability of adjacent structures including buildings, roadways, etc. 4g. Protect the excavation from water entry 4h. Do not work in excavations where there is standing water. 4i. Provide safe access to and from the excavation – ramps, stairs, ladders. 4j. When persons will be in or around an excavation, a Competent Person shall inspect the excavation, the adjacent areas, and protective systems daily: before each work shift; throughout the work shifts as dictated by the work being done; after every rainstorm; after other events that could increase hazards, e.g., snowstorm, windstorm, thaw, earthquake, etc.; when fissures, tension cracks, sloughing, undercutting, water seepage, bulging at the bottom or other similar conditions occur; when there is a change in size, location or placement of the spoil pile; and where there is any indication or change in adjacent structures. (EM 385-1-1 Sec 25.A.02)
3. Work in/around excavation/ trench.	1. Cave in / Collapse. 2. Fall from excavation / trench edge. 3. Inability to egress especially in an emergency. 4. Changes in soil conditions / atmospheric conditions in trench (confined space hazards).	1, 2, 3, and 4 – same controls as Step 2 above.

	5. Traffic hazards.	
4. Close excavation / trench.	1. Struck by/ caught between heavy equipment. 2. Cave in / Collapse. 3. Traffic hazard.	All controls outlined in steps 1, 2, and 3 above. All excavation hazards exist and must be controlled until the excavation is properly closed..
EQUIPMENT	INSPECTION REQUIREMENTS	TRAINING REQUIREMENTS
Hand shovels and tools Excavation equipment	Tool inspections Equipment Inspections Daily plus excavation inspection	Competent person qualification training (EM 385-1-1 Sec 25.A.02.b) Equipment operator training.
 Prepared by: <Xxx Xxxx, xxxx> <i>(Contractor's competent/qualified person signature)</i>		
<input checked="" type="checkbox"/> - AHA Accepted as part of project Accident Prevention Plan		Signature: <Xxxx>  Date: MM/dd/yy



ACTIVITY HAZARD ANALYSIS		
ID No.	G-5	FEATURE OF WORK: GENERIC AHA – Electrical
Contract No. N33191-XX-X-XXXX	Project: Xxxx	Location: Xxxx, XXXX
Date: MM/dd/yy	Activity:	Estimated Start Date:
PRINCIPAL STEPS	POTENTIAL SAFETY / HEALTH HAZARDS	RECOMMENDED CONTROLS
1. Provide temporary power to the construction project and potentially the building occupants.	1. Falls 2. Electrocution	NOTE: All items hazards and controls in generic AHA G1: Mobilization and General Construction Safety apply to this activity. 1a. Provide safe work platform and access to all work areas (see generic AHA G3 – scaffolding/fall protection). 1b. Protect all openings in work surfaces from falls. 1c. Do not use drums or other unstable objects as work platforms. 2a. Use only qualified person, electrical (EM 385-1-1, App Q) to perform all electrical work. 2b. Use only CE or UL approved wiring and equipment. 2c. All work must comply with NEC or CE code requirements. 2d. Insure that before work is begun the circuit is de-energized and free from stored energy. Comply with the specific requirements in EM 385-1-1 (e.g. Lockout/Tagout – Control of Hazardous Energy – Sec 12 and 11.A.02 – Isolation) 2e. Provide temporary power from a properly grounded source through a 10mA GFCI protected weatherproof panel. 2f. Protect all circuits from overload by circuit breakers or other approved overload protection methods. 2g. Maintain ground throughout the temporary power circuit to portable hand tools, and other equipment unless the tool is double insulated and marked as such. 2h. Comply with all other provisions of EM 385-1-1 Section 11 (e.g. 11.E temporary wiring and lighting – sketch of plan, testing, clearance, wet locations, etc.)
2. Remove / de-commission existing wiring and electrical equipment.	1. Falls 2. Electrocution	All controls listed in Step 1 apply to this step also. 1a. Provide safe work platform and access to all work areas (see generic AHA G3 – scaffolding/fall protection). 1b. Protect all openings in work surfaces from falls. 1c. Do not use drums or other unstable objects as work platforms. 2a. All controls identified above – plus: 2b. Control of Hazardous energy – Lock Out / Tag Out. Due to potential for poor understanding of existing wiring service special care must be used to test all circuits prior to removal / de-commissioning. 2c. Warning: stored energy in capacitors and other electrical equipment can present an electrocution hazard even after it is disconnect from a power supply. Stored energy must be dissipated prior to handling.
3. Install new wiring and electrical equipment	1. Falls 2. Electrocution	All controls listed in Step 1 apply to this step also. 1a. Provide safe work platform and access to all work areas (see generic AHA G3 – scaffolding/fall protection). 1b. Protect all openings in work surfaces from falls. 1c. Do not use drums or other unstable objects as work platforms. 2a. All controls identified above – plus: 2b. Exercise special care to identify energized temporary electrical wiring from non-energized new wiring. 2c. Do not use permanent wiring to provide temporary power without specific plan for identifying energized circuits.
4. Remove temporary	1. Falls	All controls listed in Step 1 apply to this step also.

power and energize permanent system.	2. Electrocution	1a. Provide safe work platform and access to all work areas (see generic AHA G3 – scaffolding/fall protection). 1b. Protect all openings in work surfaces from falls. 1c. Do not use drums or other unstable objects as work platforms. 2a. All controls identified above – plus: 2b. De-energize all temporary power
EQUIPMENT	INSPECTION REQUIREMENTS	TRAINING REQUIREMENTS
Hand and power tools Specialized electrical tools and equipment	Tool and equipment inspections Lock-Out / Tag-Out inspections for stored energy	Competent person training and qualification
 Prepared by: <Xxx Xxxx, xxxx> <i>(Contractor's competent/qualified person signature)</i>		
<input checked="" type="checkbox"/> - AHA Accepted as part of project Accident Prevention Plan		Signature: <Xxxx>  Date: MM/dd/yy

Annex 2: Guideline to Prepare the Quality Control Plan

Immediately after award, the contractor shall prepare a Quality Control Plan following the guideline and format provided in this Annex 2. This is in addition to any quality control plan or documentation that may be required by Montenegro regulations for this type of construction activity. The Plan shall be accepted by the Contracting Officer before works are authorized to start at the job site.

[Project Title]
[Contract Number]

QUALITY CONTROL PLAN

The purpose of this paper is to illustrate how our site organization, our staff and our procedures will help ensure the quality required by the technical requirements.

SITE ADMINISTRATION

[Describe how to carry out all formalities required by local law to open and run the worksite]

SITE FACILITIES

[Describe how the specific worksite is going to be delimited and organized]

STAFF SITE

[List the roles and relevant names of the staff to be employed on the worksite; provide a short description if necessary]

CONTROL ORGANIZATION

[Detail how it will work; who does what]

TESTING

[Describe how tests of soil and concrete will be conducted]

CHECKING THE QUALITY OF THE WORKS

[Describe]

CONTROL OF MATERIALS

[Describe]

GENERAL CONSTRUCTION CONTROL ACTIVITIES

[Describe]

SAFETY ON SITE

[Describe]