

Did You buy these plans?
Great thanks for You

If You download these plans from our website or You received them from the different source - You should pay for these plans. A few euro will be enough...
You will help us create new plans of warships.

You can use the active link below:
<http://profilemorskie.home.pl//350.htm>

Thanks

VITTORIO VENETO

(1941)

1:350

ALL RIGHTS RESERVED

No part of this publication may be reproduced, stored in retrieval system or transmitted in any form by any means electrical, mechanical or otherwise, without first seeking the written permission of the copyright owner.

Copyright © by

FIRMA WYDAWNICZO-HANDLOWA BS

POLAND

**This plans are supplementing the PROFILE MORSKIE
publication No. 122 (VITTORIO VENETO)**

Warships Plans - PROFILE MORSKIE No 122

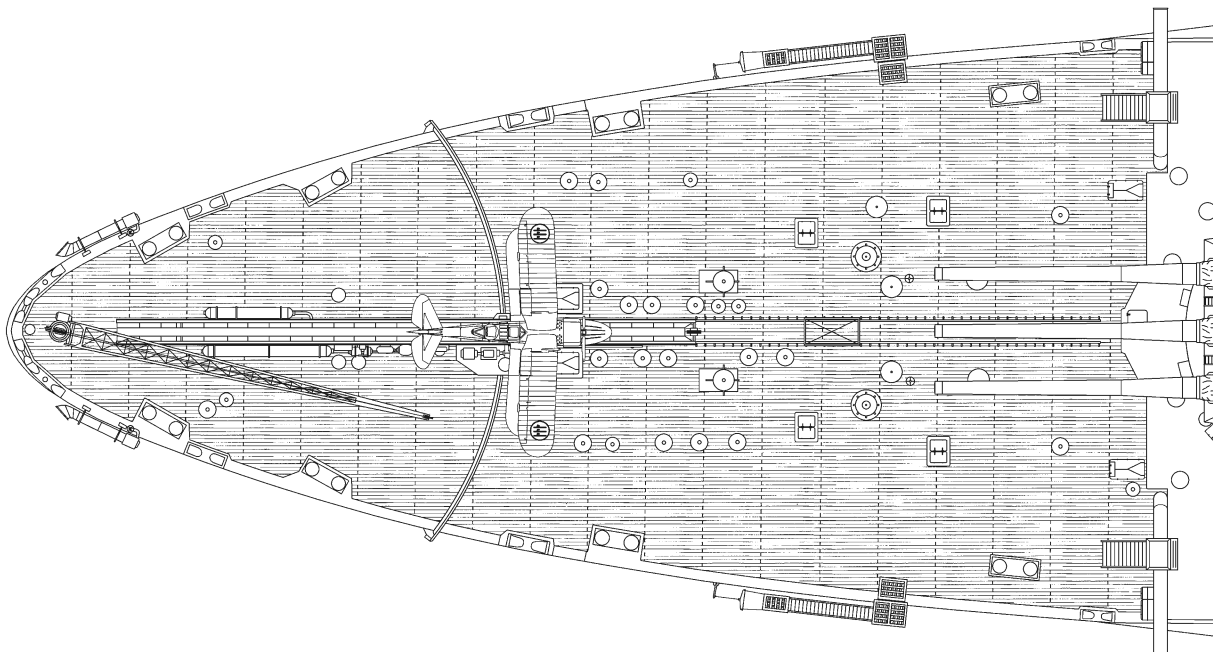
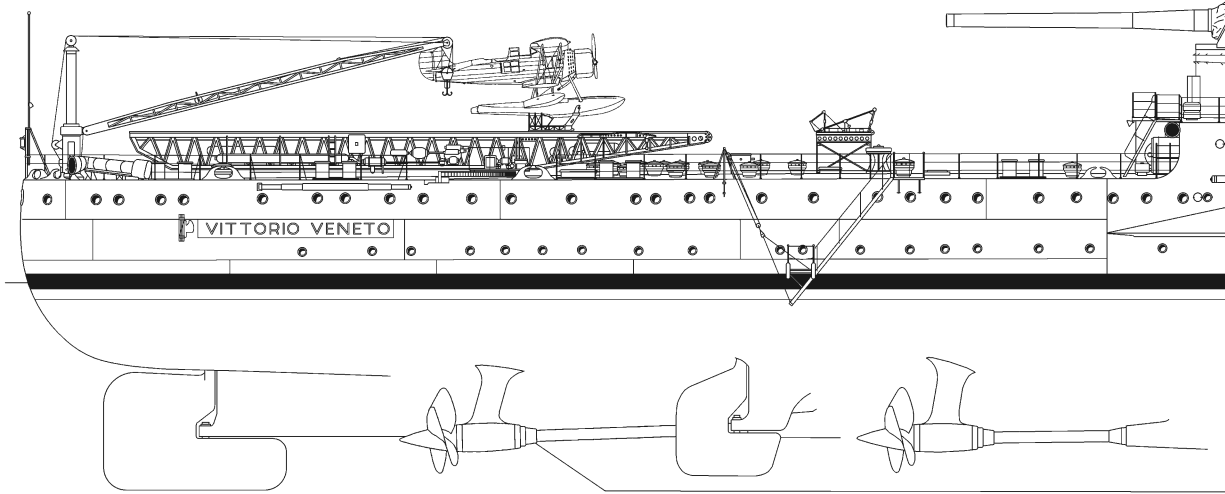
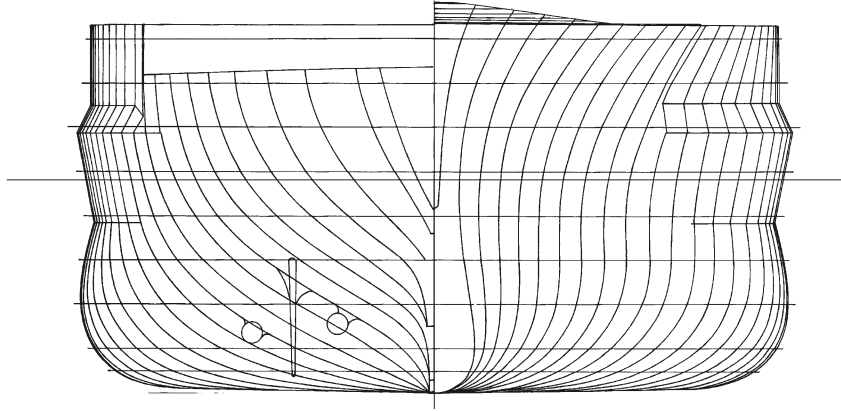

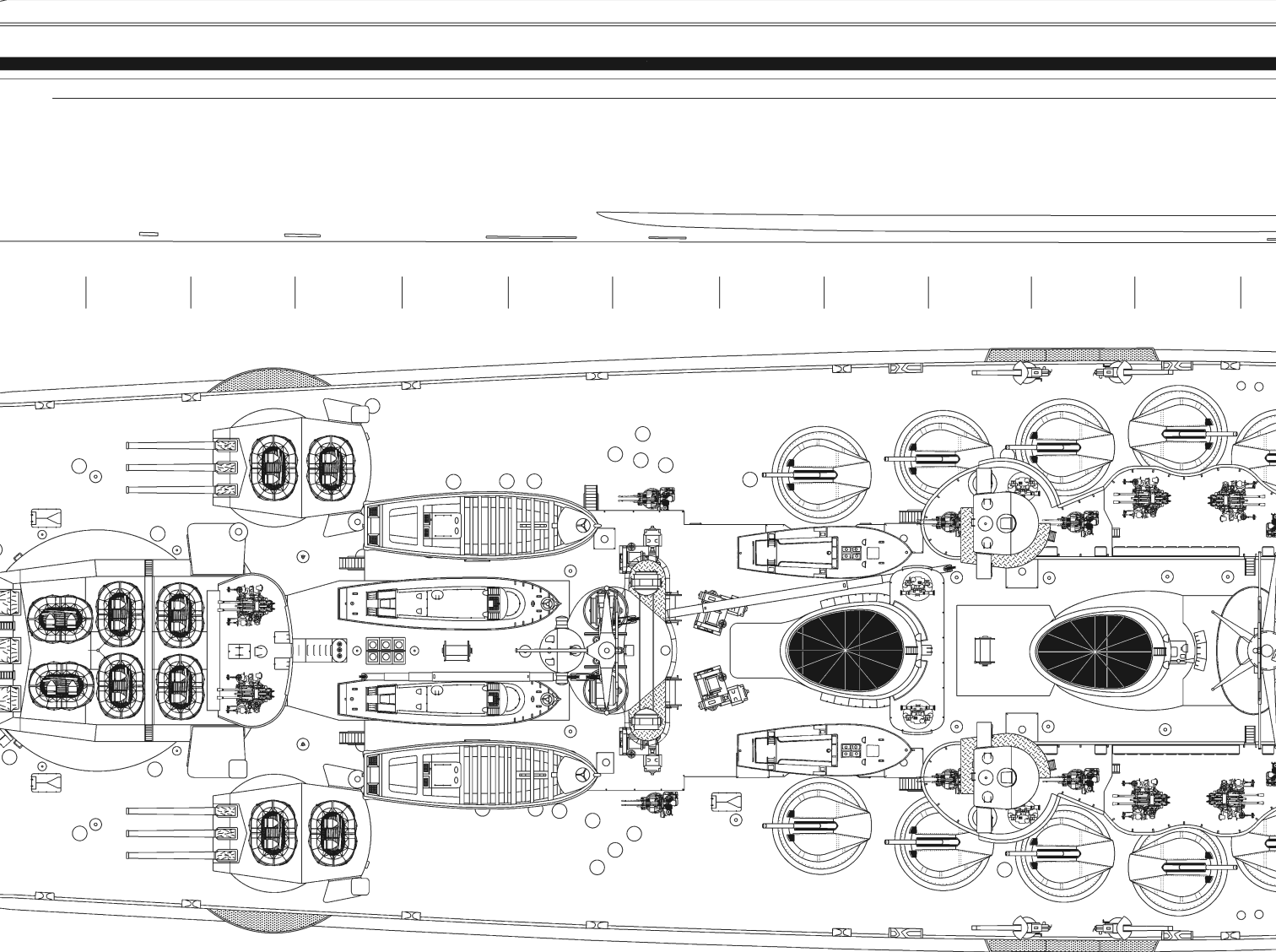
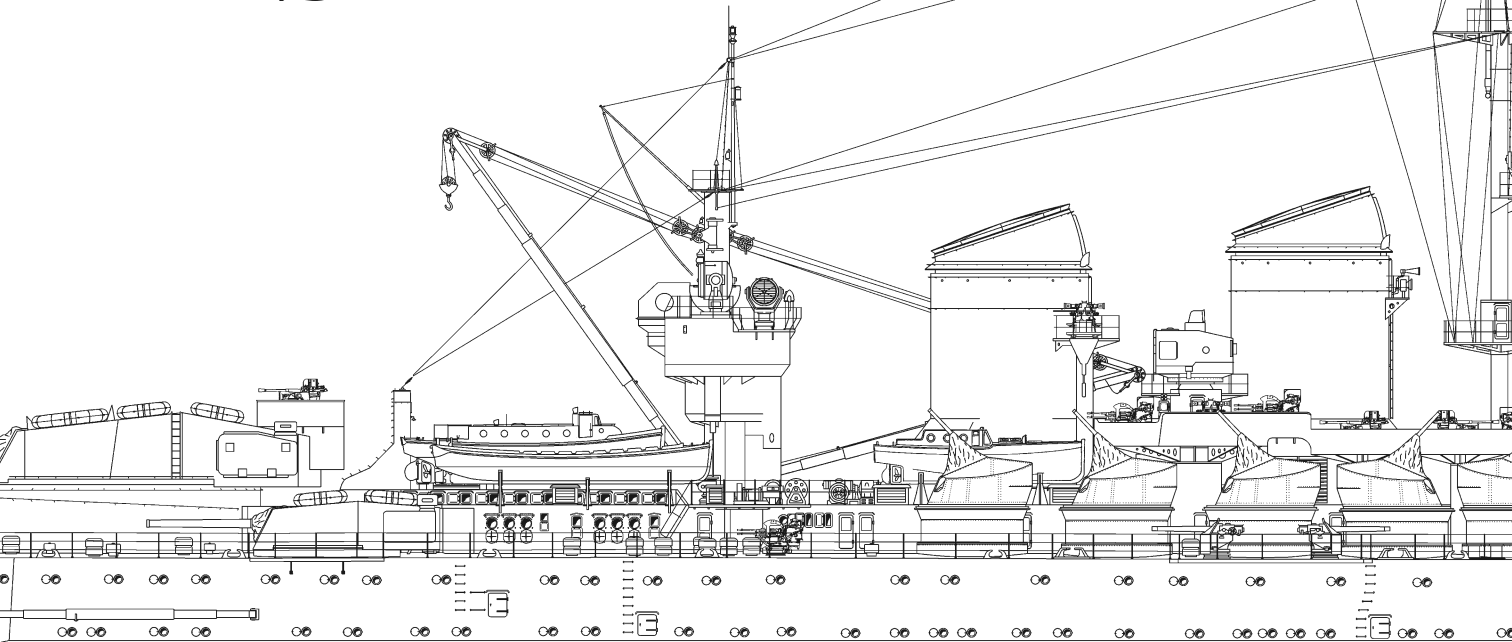

VITTORIO VENETO

(1941)

1:350

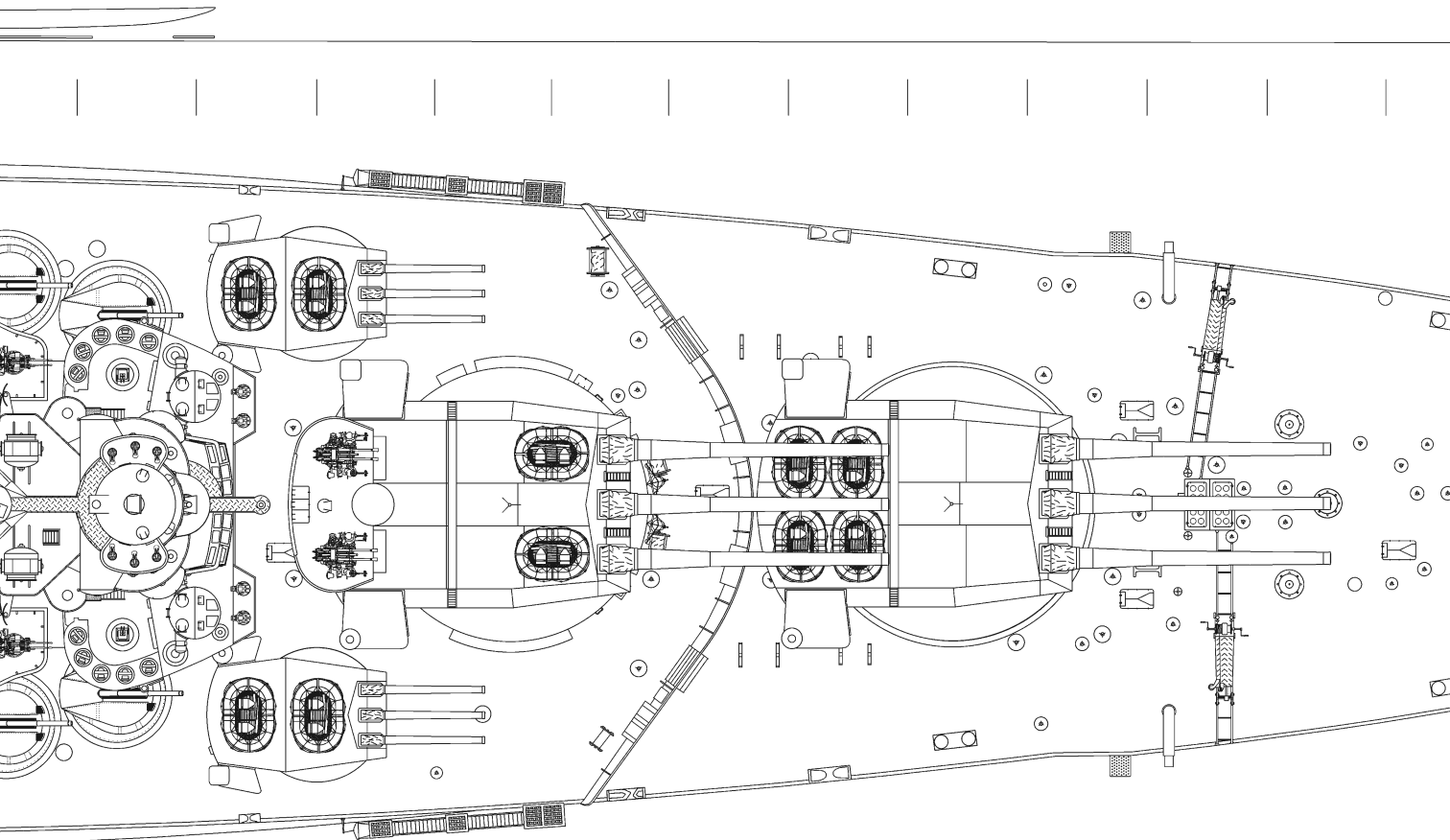

NETO

Położenie stępki (Laid down) 28.10.1934.
 Wodowanie (Launched) 22.08.1937.
 Oddanie do służby (Completed) 06.05.1940.

Stocznia (Builder) Cantieri Riuniti dell' Adriatico, Trieste
 Wyporność (Displacement) 41167 t* (light);
 45752 t* (pełna / full load).

Długość (Length) 237,70 m. (całkowita / oa).
 Szerokość (Beam) 32,9 m.
 Zanurzenie (Draught) 10,5 m.

Maszyny (Machinery) cztery turbiny Beluzzo mocy 139561 KM;
 osiem kotłów Yarrow / four turbines Beluzzo
 (139561 SHP), eight boilers Yarrow type.

Prędkość (Speed) 31,2 w/ kts (projekt)

Paliwo (Bunkerage) 4210t* (max).

Zasięg (Range) 4580 Mm przy 16 w / 4580 nm at 16 kts;

Uzbrojenie (Armament) 9 x 381 mm (3x3)
 12 x 152 mm (4x3)
 12 x 90 mm (12x1)
 16 x 37 mm (8x2)
 16 x 20 mm (8x2)

Opancerzenie (Armour) 350 mm - burty/ belt; 207 mm - pokład / deck;
 350 mm barbety /barbettes;
 380 mm - 350 mm wieże / turrets

Załoga (Complement) 1866 ludzi /men.

* 1 t = 1016 kg;

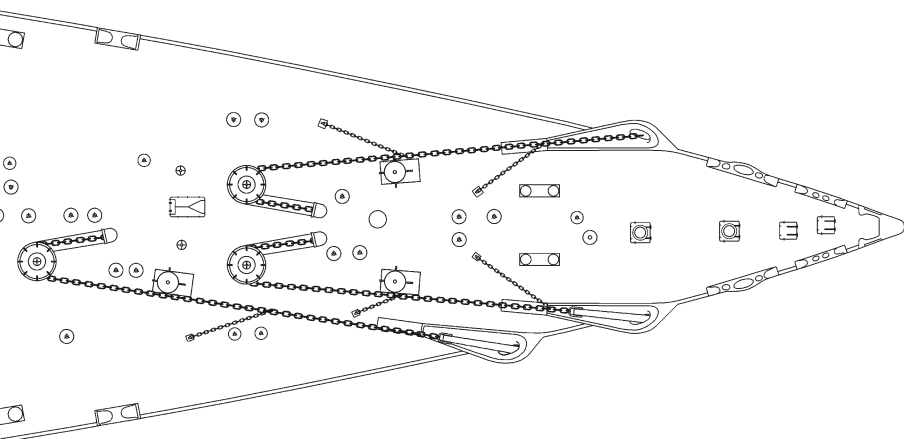
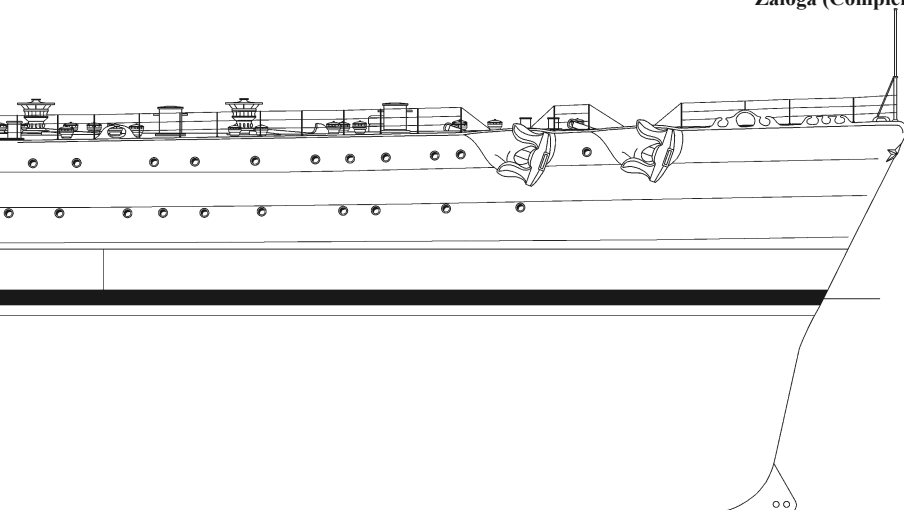

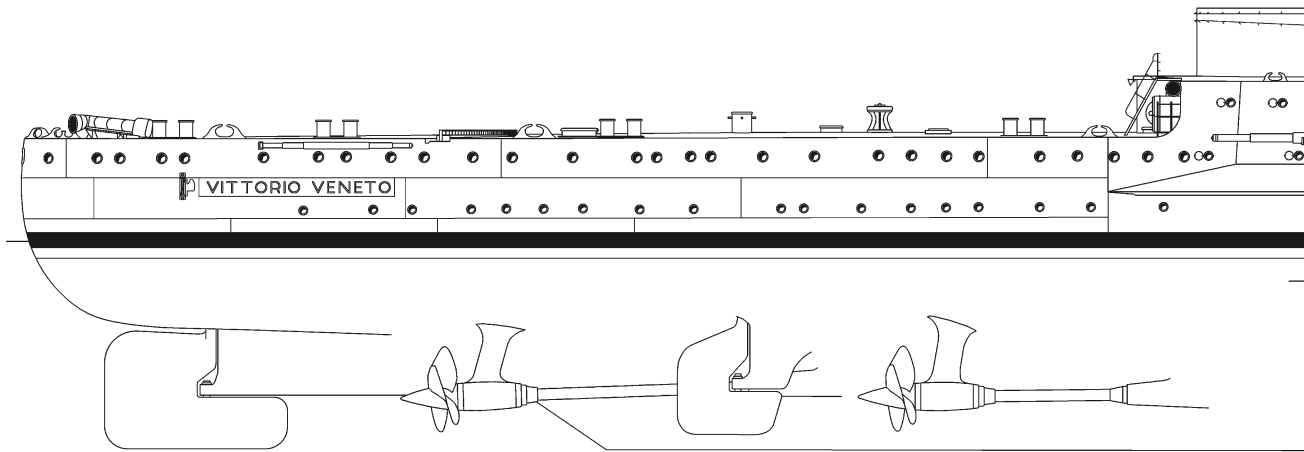

This plans are supplementing the PROFILE MORSKIE publication No. 122 (VITTORIO VENETO)

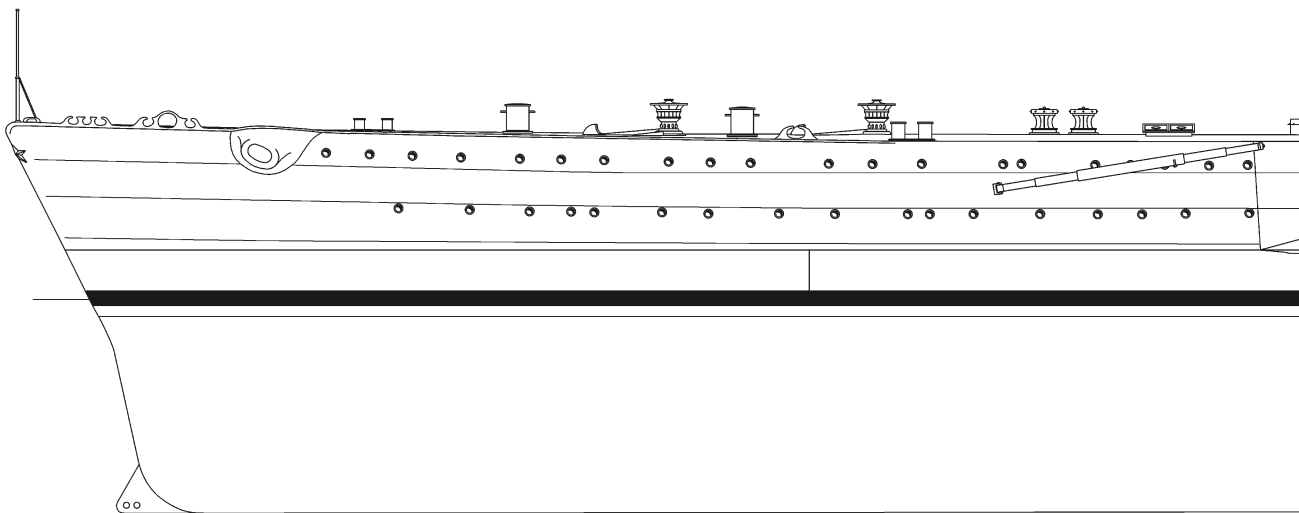
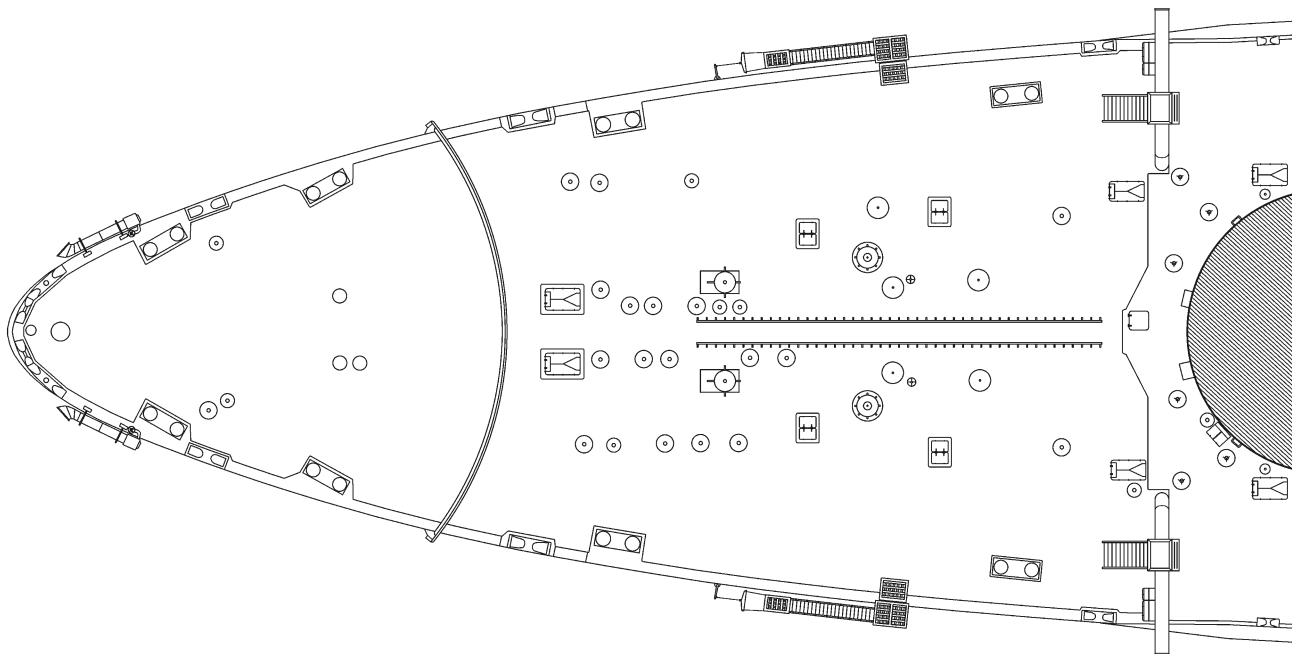

Warships Plans - PROFILE MORSKIE No 122

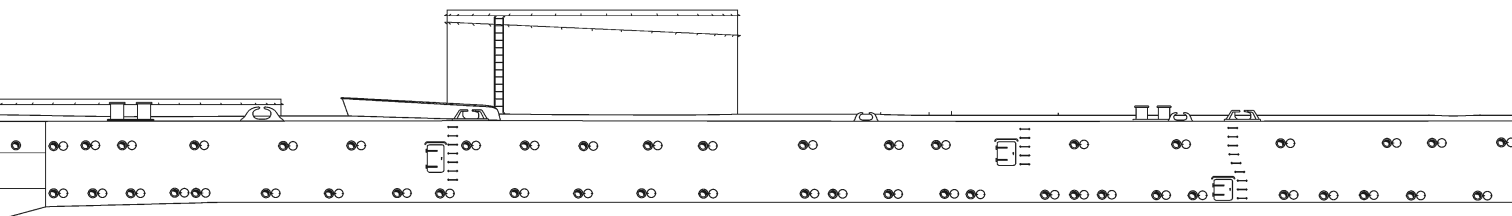
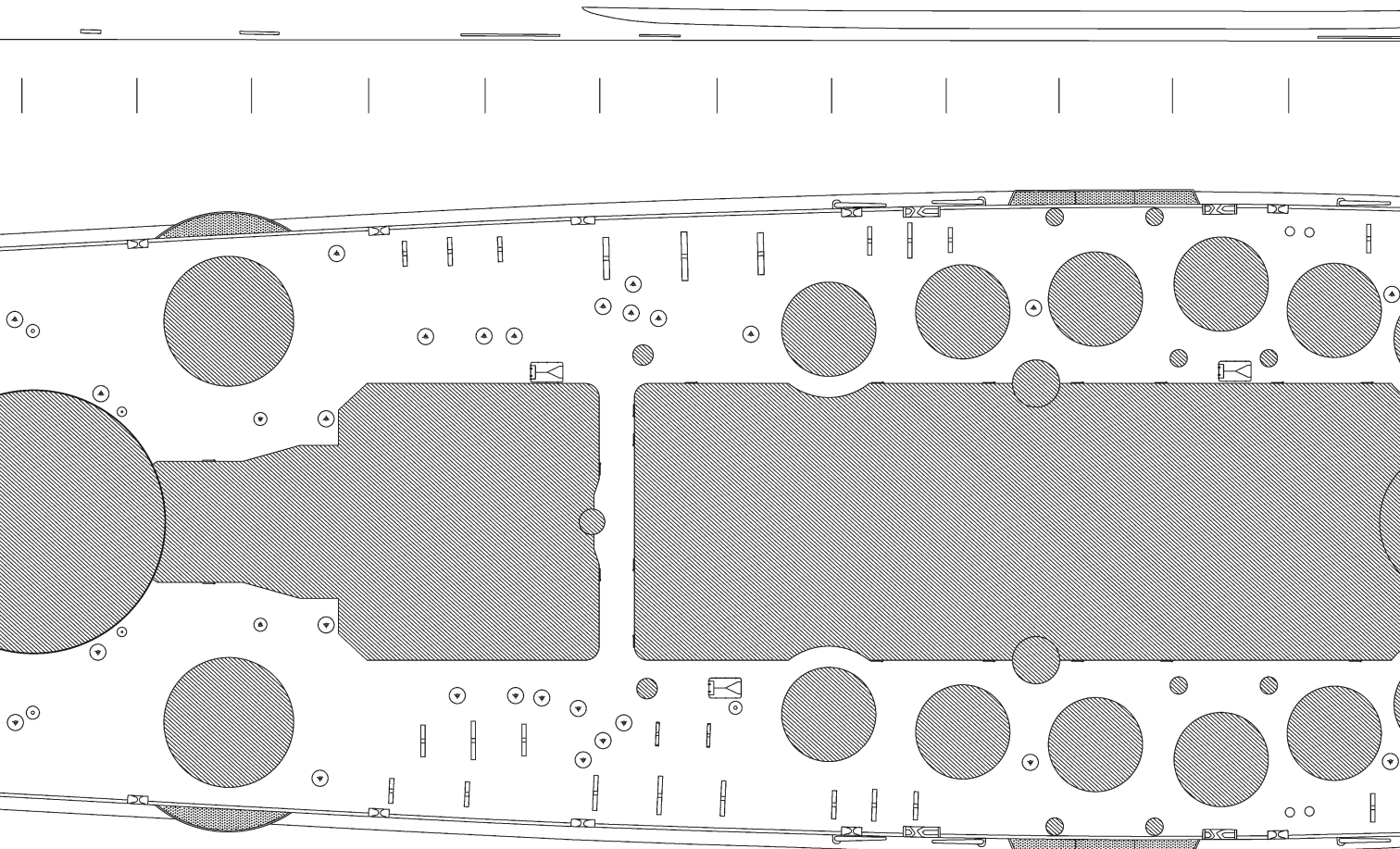
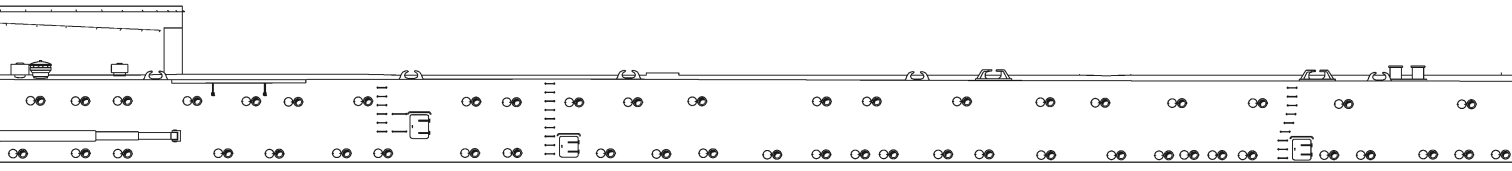

Warships Plans - PROFILE MORSKIE No 122

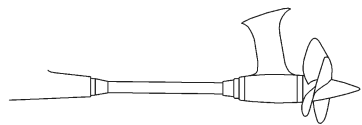
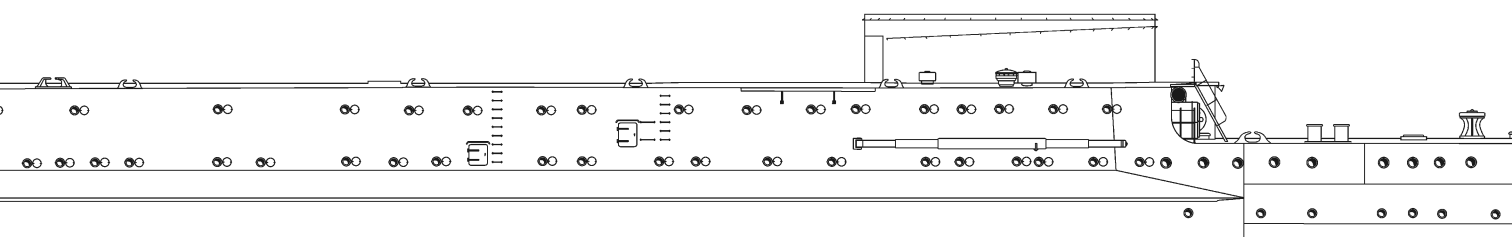
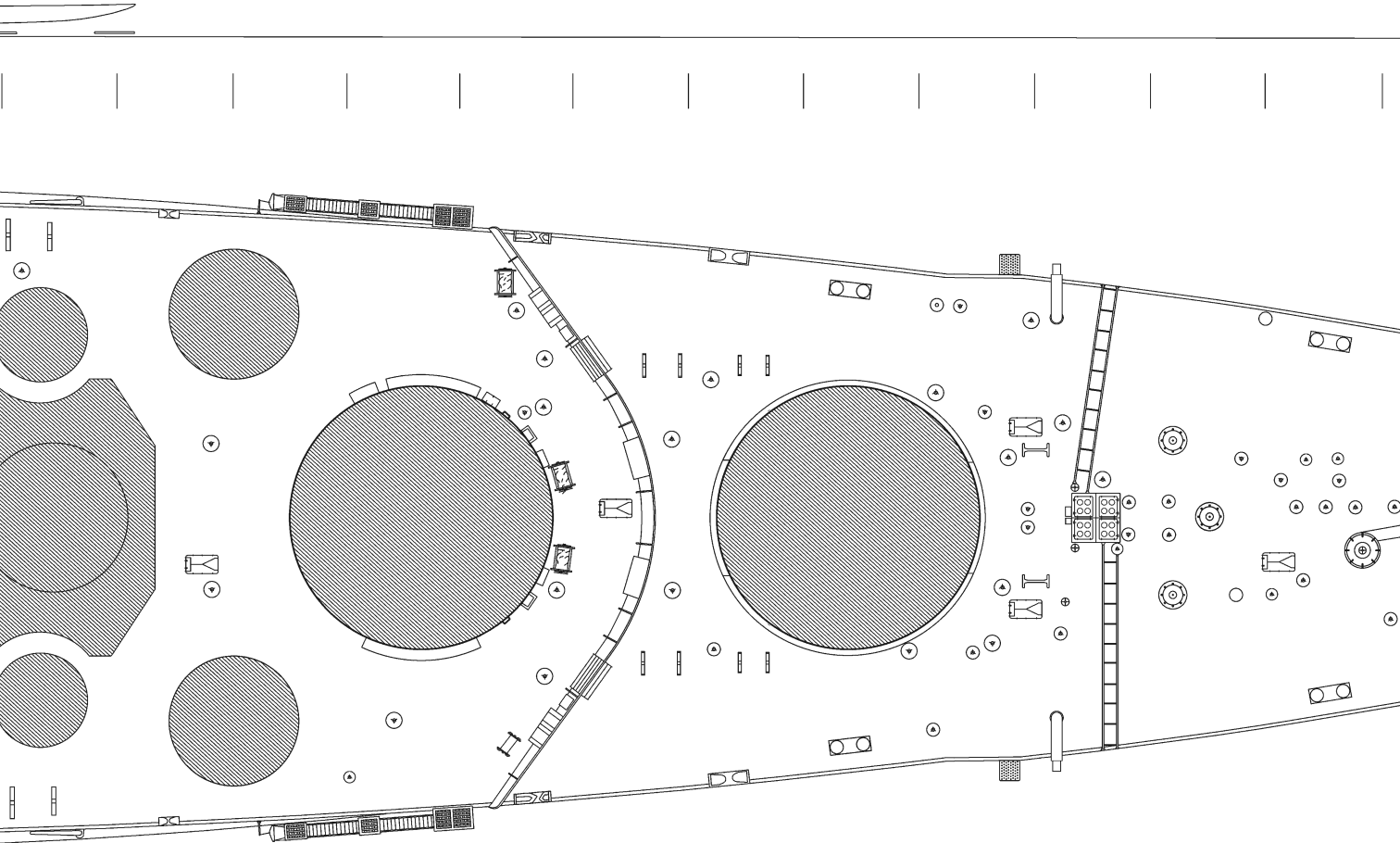
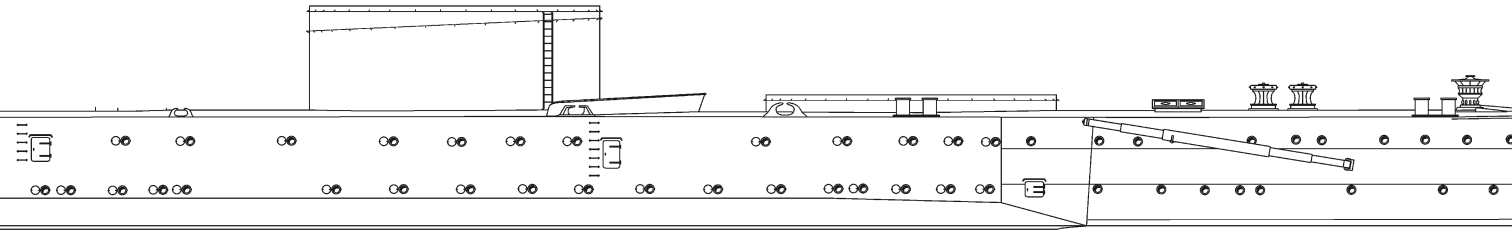

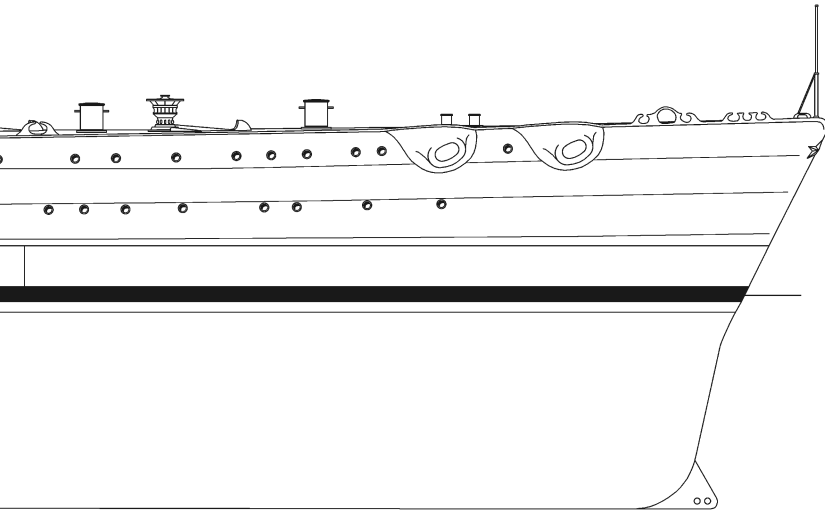

VITTORIO VENETO

(1941)

1:350

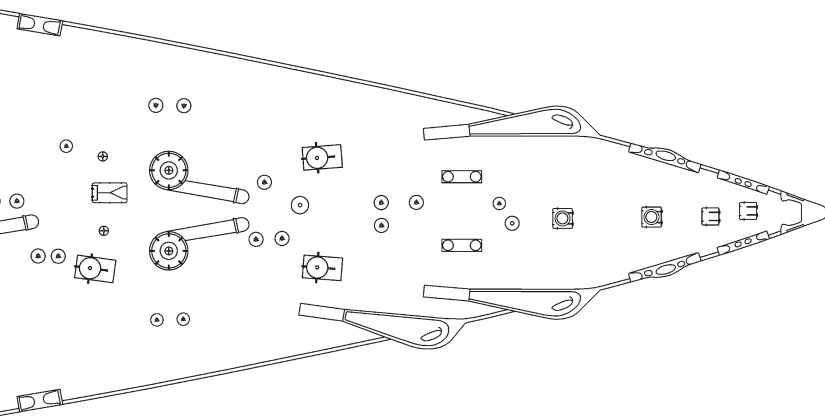

ALL RIGHTS RESERVED

No part of this publication may be reproduced, stored in retrieval system or transmitted in any form by any means electrical, mechanical or otherwise, without first seeking the written permission of the copyright owner.

Copyright © by

FIRMA WYDAWNICZO-HANDLOWA **BS**

POLAND

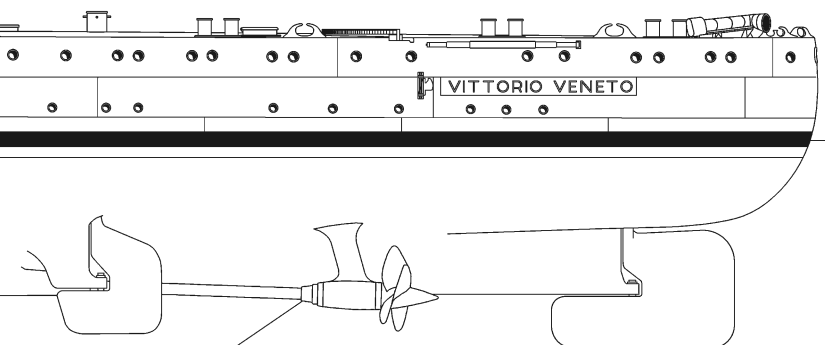

ALL RIGHTS RESERVED

No part of this publication may be reproduced, stored in retrieval system or transmitted in any form by any means electrical, mechanical or otherwise, without first seeking the written permission of the copyright owner.

Copyright © by

FIRMA WYDAWNICZO-HANDLOWA BS

POLAND

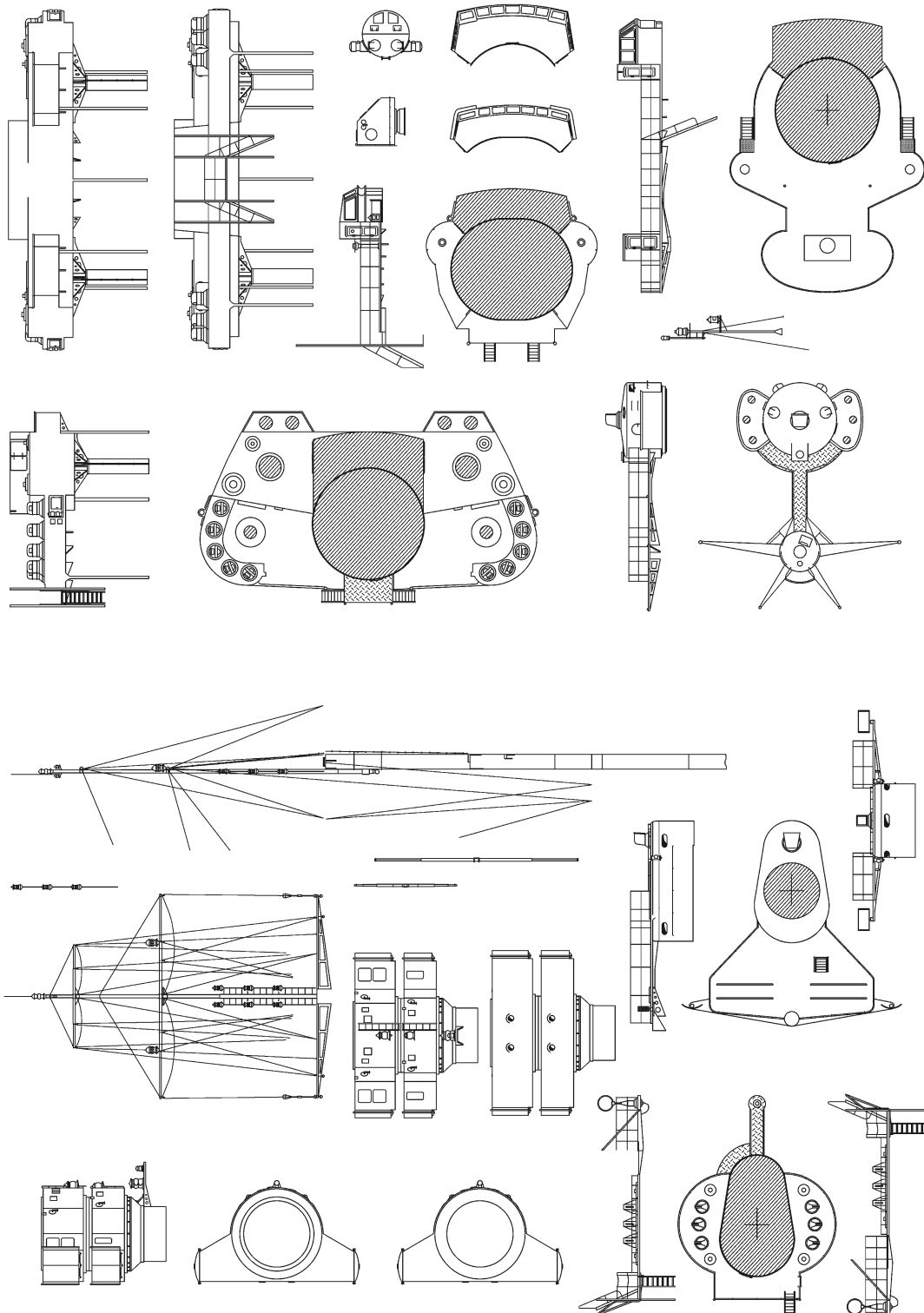

ALL RIGHTS RESERVED

No part of this publication may be reproduced, stored in retrieval system or transmitted in any form by any means electrical, mechanical or otherwise, without first seeking the written permission of the copyright owner.

Copyright © by

FIRMA WYDAWNICZO-HANDLOWA BS

POLAND

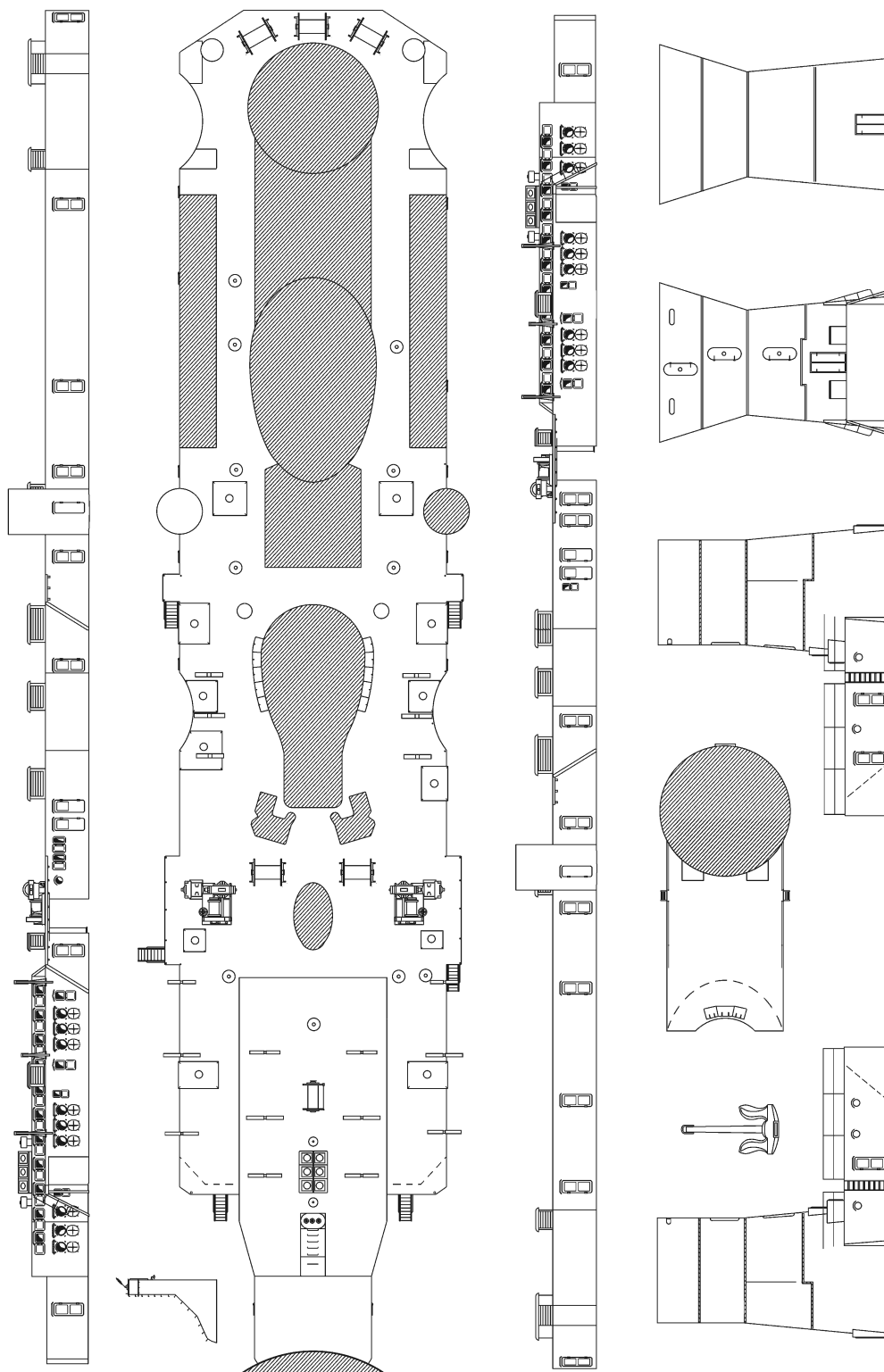

ALL RIGHTS RESERVED

No part of this publication may be reproduced, stored in retrieval system or transmitted in any form by any means electrical, mechanical or otherwise, without first seeking the written permission of the copyright owner.

Copyright © by

FIRMA WYDAWNICZO-HANDLOWA BS

POLAND

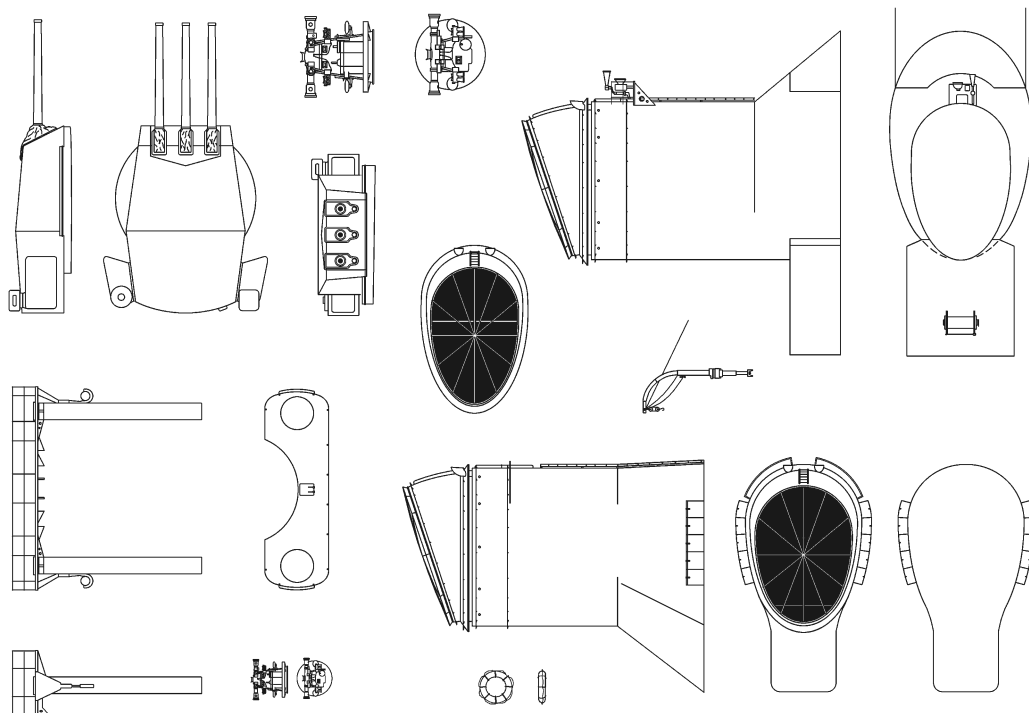
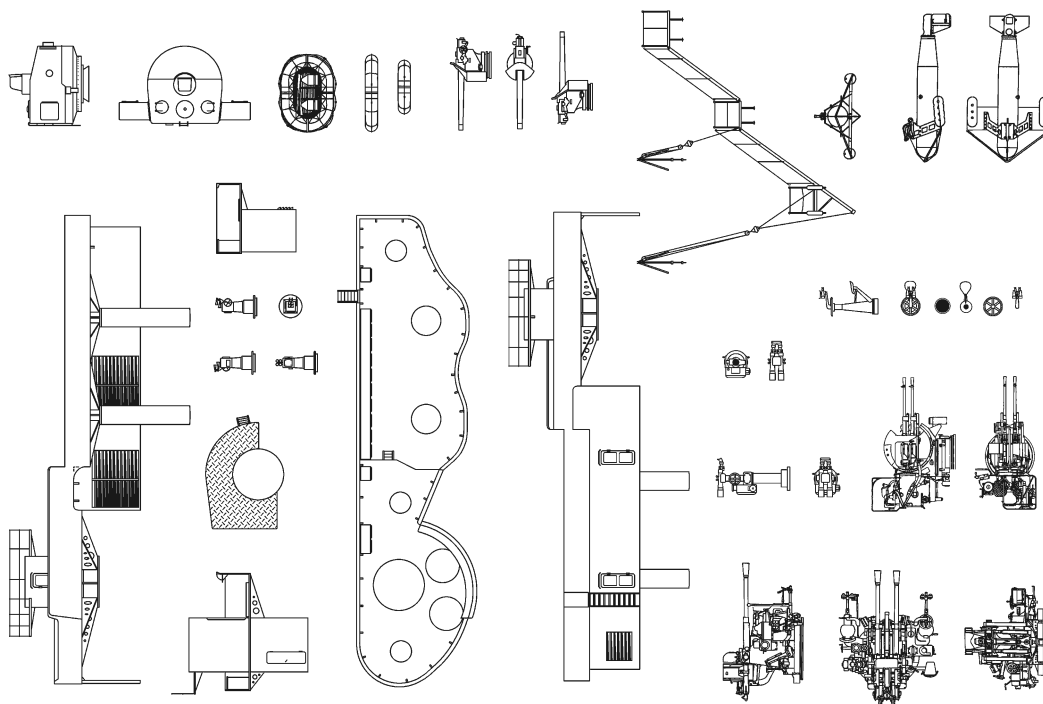

ALL RIGHTS RESERVED

No part of this publication may be reproduced, stored in retrieval system or transmitted in any form by any means electrical, mechanical or otherwise, without first seeking the written permission of the copyright owner.

Copyright © by

FIRMA WYDAWNICZO-HANDLOWA BS

POLAND

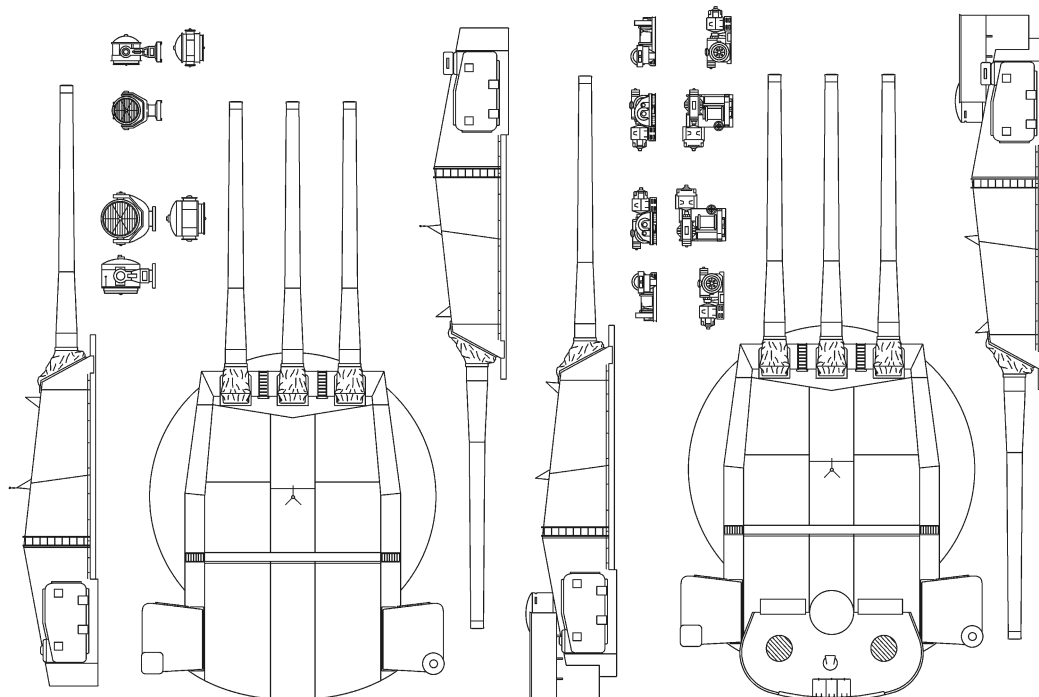
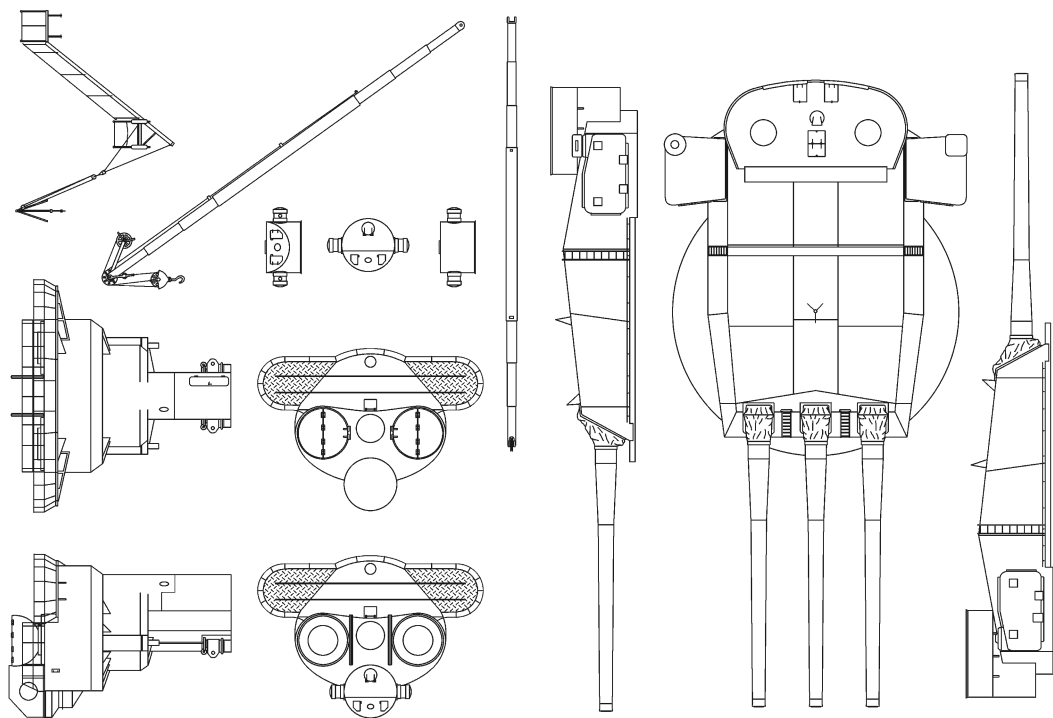

ALL RIGHTS RESERVED

No part of this publication may be reproduced, stored in retrieval system or transmitted in any form by any means electrical, mechanical or otherwise, without first seeking the written permission of the copyright owner.

Copyright © by

**FIRMA WYDAWNICZO-HANDLOWA BS
POLAND**

